

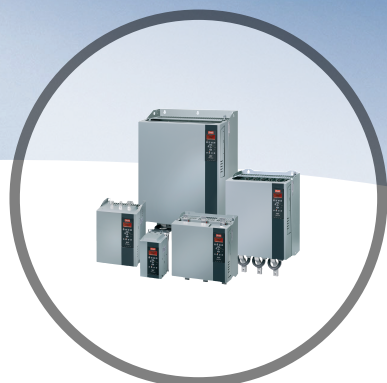

Operating Instructions

VLT[®] Soft Starter MCD 500



Contents

1 Safety	6
1.1 Warnings	6
2 Introduction	8
3 Installation	10
3.1 Mechanical Installation	10
3.2 Dimensions and Weights	11
4 Electrical Installation	13
4.1 Control Wiring	13
4.1.1 Ways to Control the Soft Starter	13
4.1.2 Control Terminals	13
4.1.3 Remote Inputs	13
4.1.4 Serial Communication	14
4.1.5 Ground Terminal	14
4.1.6 Power Terminations	15
4.2 Power Input and Output Configurations	16
4.2.1 Internally Bypassed Models (MCD5-0021B to MCD5-0961B)	16
4.2.2 MCD5-0245C	17
4.2.3 MCD5-0360C to MCD5-1600C	17
4.3 Motor Connection	17
4.3.1 Testing the Installation	17
4.3.2 In-line Installation	18
4.3.2.1 Internally Bypassed	18
4.3.2.2 Non-bypassed	18
4.3.2.3 Externally Bypassed	18
4.3.3 Inside Delta Installation	19
4.3.3.1 Internally Bypassed	19
4.3.3.2 Non-bypassed	19
4.3.3.3 Externally Bypassed	20
4.4 Current Ratings	20
4.4.1 In-line Connection (Bypassed)	21
4.4.2 In-line Connection (Non-bypassed/Continuous)	22
4.4.3 Inside Delta Connection (Bypassed)	23
4.4.4 Inside Delta Connection (Non-bypassed/Continuous)	24
4.5 Minimum and Maximum Current Settings	25
4.6 Bypass Contactor	26
4.7 Main Contactor	26
4.8 Circuit Breaker	26

4.9 Power Factor Correction	26
4.10 Fuses	26
4.10.1 Power Supply Fuses	26
4.10.2 Bussmann Fuses	27
4.10.3 Ferraz Fuses	29
4.10.4 UL Fuse Selection and Short Circuit Ratings	31
4.11 Schematic Diagrams	33
5 Product Features	35
5.1 Motor Overload Protection	35
5.2 Adaptive Control	35
5.3 Starting Modes	36
5.3.1 Constant Current	36
5.3.2 Current Ramp	36
5.3.3 Adaptive Control	36
5.3.4 Kick Start	37
5.4 Stopping Modes	37
5.4.1 Coast to Stop	37
5.4.2 TVR Soft Stop	37
5.4.3 Adaptive Control	38
5.4.4 Pump Stopping	38
5.4.5 Brake	38
5.5 Jog Operation	39
5.6 Inside Delta Operation	40
5.7 Typical Start Currents	41
5.8 Installation with Main Contactor	42
5.9 Installation with Bypass Contactor	43
5.10 Emergency Run Operation	44
5.11 Auxiliary Trip Circuit	45
5.12 DC Brake with External Zero-speed Sensor	46
5.13 Soft Braking	47
5.14 Two-speed Motor	48
6 Operation	50
6.1 Control Methods	50
6.2 Operation and LCP	51
6.2.1 Operating Modes	51
6.3 Remote Mounted LCP	52
6.3.1 Synchronising the LCP and the Soft Starter	52
6.4 Welcome Screen	52
6.5 Local Control Keys	52

6.6 Displays	52
6.6.1 Temperature Monitoring Screen (S1)	53
6.6.2 Programmable Screen (S2)	53
6.6.3 Average Current (S3)	53
6.6.4 Current Monitoring Screen (S4)	53
6.6.5 Frequency Monitoring Screen (S5)	53
6.6.6 Motor Power Screen (S6)	53
6.6.7 Last Start Information (S7)	53
6.6.8 Date and Time (S8)	53
6.6.9 SCR Conduction Bargraph	54
6.6.10 Performance Graphs	54
7 Programming	55
7.1 Access Control	55
7.2 Quick Menu	55
7.2.1 Quick Set-up	55
7.2.2 Application Set-up Examples	56
7.2.3 Loggings	57
7.3 Main Menu	57
7.3.1 Parameters	57
7.3.2 Parameter Shortcut	57
7.3.3 Parameter List	58
8 Parameter Descriptions	59
8.1 Primary Motor Settings	59
8.1.1 Brake	60
8.2 Protection	60
8.2.1 Current Imbalance	60
8.2.2 Undercurrent	61
8.2.3 Instantaneous Overcurrent	61
8.2.4 Frequency Trip	61
8.3 Inputs	62
8.4 Outputs	63
8.4.1 Relay A Delays	63
8.4.2 Relays B and C	63
8.4.3 Low Current Flag and High Current Flag	64
8.4.4 Motor Temperature Flag	64
8.4.5 Analog Output A	64
8.5 Start/Stop Timers	64
8.6 Auto-Reset	65
8.6.1 Auto-Reset Delay	65

8.7 Secondary Motor Set	65
8.8 Display	67
8.8.1 User Programmable Screen	67
8.8.2 Performance Graphs	68
8.9 Restricted Parameters	68
8.10 Protection Action	69
8.11 Factory Parameters	69
9 Tools	70
9.1 Set Date and Time	70
9.2 Load/Save Settings	70
9.3 Reset Thermal Model	70
9.4 Protection Simulation	71
9.5 Output Signal Simulation	71
9.6 Digital I/O State	71
9.7 Temp Sensors State	72
9.8 Alarm Log	72
9.8.1 Trip Log	72
9.8.2 Event Log	72
9.8.3 Counters	72
10 Troubleshooting	73
10.1 Trip Messages	73
10.2 General Faults	78
11 Specifications	80
11.1 UL Compliant Installation	82
11.1.1 Models MCD5-0021B to MCD5-0105B	82
11.1.2 Models MCD5-0131B to MCD5-0215B	82
11.1.3 Models MCD5-0245B to MCD5-0396B	82
11.1.4 Models MCD5-0245C	82
11.1.5 Models MCD5-0360C to MCD5-1600C	82
11.1.6 Models MCD5-0469B to MCD5-0961B	82
11.1.7 Pressure Terminal/Connector Kits	82
11.2 Accessories	82
11.2.1 LCP Remote Mounting Kit	82
11.2.2 Communication Modules	82
11.2.3 PC Software	83
11.2.4 Finger Guard Kit	83
11.2.5 Surge Protection Kit (Lightning Protection)	83
12 Busbar Adjustment Procedure (MCD5-0360C to MCD5-1600C)	84

13 Appendix	86
13.1 Symbols, Abbreviations, and Conventions	86
Index	87

1 Safety

1.1 Warnings

When reading this manual, pay special attention to the following symbols:

NOTICE

Useful hints for the reader.

CAUTION

Indicates a general warning.

WARNING

Indicates a high-voltage warning.

The examples and diagrams in this manual are included solely for illustrative purposes. The information contained in this manual is subject to change at any time and without prior notice. Responsibility or liability is under no circumstances accepted for direct, indirect, or consequential damages resulting from the use or application of this equipment.

NOTICE

Before changing any parameter settings, save the current parameter to a file using MCD PC Software or the *Save User Set* function.

WARNING

WARNING - ELECTRICAL SHOCK HAZARD

VLT® Soft Starters MCD 500 contain dangerous voltages when connected to mains voltage. Only a competent electrician should carry out the electrical installation. Improper installation of the motor or the soft starter can cause equipment failure, serious injury, or death. Follow the guidelines in this manual and local electrical safety codes.

Models MCD5-0360C ~ MCD5-1600C:

Treat the bus bar and heat sink as live whenever the unit has mains voltage connected (including when the soft starter is tripped or waiting for a command).

WARNING

Disconnect the soft starter from mains voltage before carrying out repair work.

It is the responsibility of the person installing the soft starter to provide proper grounding and branch circuit protection according to local electrical safety codes.

Do not connect power factor correction capacitors to the output of MCD 500 soft starters. If static power factor correction is employed, it must be connected to the supply side of the soft starter.

MCD5-0021B ~ MCD5-961B:

After transportation, mechanical shock, or rough handling there is a risk that the bypass contactor has latched into the On state. To prevent the motor from starting immediately, on first commissioning, or operation after transportation, always ensure that the control supply is applied before the power. Applying control supply before power ensures that the contactor state is initialised.

WARNING

SAFETY OF PERSONNEL

The soft starter is not a safety device and does not provide electrical isolation or disconnection from the supply.

- If isolation is required, the soft starter must be installed with a main contactor.
- The start and stop functions of the soft starter must not be relied upon for personnel safety. Faults occurring in the mains supply, the motor connection, or the electronics of the soft starter, can cause unintended motor starts or stops.

To provide machine or personnel safety, control the isolation device through an external safety system.

In *Auto On* mode, the motor can be controlled remotely (via remote inputs) while the soft starter is connected to mains.

CAUTION

These stop functions are not sufficient to avoid unintended start.

If faults occur in the electronics of the soft starter, a motor that has been stopped may start. A temporary fault in the supply mains or a cease in the motor connection can also cause a stopped motor to start.

CAUTION

Use the *Auto start* feature with caution. Read all the notes related to *Auto start* before operation.

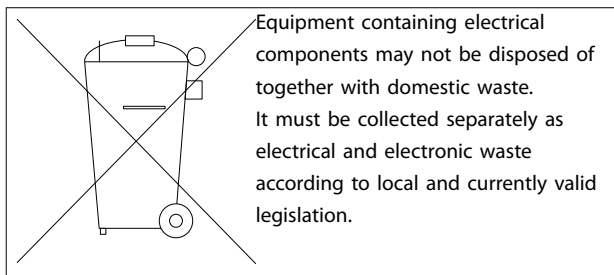

Table 1.1 Disposal Instructions

2

2 Introduction

The VLT® Soft Starter MCD 500 is an advanced digital soft start solution for motors 11–850 kW. The soft starters provide a complete range of motor and system protection features, and are designed for reliable performance in the most demanding installation situations.

2.1.1 Feature List

Models for all connection requirements

- 21–1600 A (in-line connection).
- In-line or inside delta connection.
- Internally bypassed up to 961 A.
- Mains voltage: 200–525 V AC or 380–690 V AC.
- Control voltage: 24 V AC/V DC, 110–120 V AC, or 220–240 V AC.

User-friendly LCP

- Loggings.
- Real-time graphs.
- SCR conduction bar graph.

Tools

- Application set-ups.
- Date and time stamped event log with 99 entries.
- 8 most recent trips.
- Counters.
- Protection simulation.
- Output signal simulation.

Inputs and outputs

- Local or remote control input options. (3 x fixed, 1 x programmable).
- Relay outputs (3 x programmable).
- Analog programmable output.
- 24 V DC 200 mA supply output.

Start and run modes

- Adaptive control.
- Constant current.
- Current ramp.
- Kick start.
- Jog.
- Emergency run operation.

Stop modes

- Adaptive deceleration control.
- Timed voltage ramp soft stop.
- DC brake.
- Soft brake.
- Starter disable.

Other features

- Auto start/stop timer.
- Second order thermal model.
- Battery back-up of clock and thermal model.
- Optional DeviceNet, Modbus, Ethernet, or PROFIBUS communication modules.

Comprehensive protection

- Wiring/Connection/Supply
 - Motor connection.
 - Phase sequence.
 - Power loss.
 - Individual phase loss.
 - Mains frequency.
- Current
 - Excess start time.
 - Current imbalance.
 - Undercurrent.
 - Instantaneous overcurrent.
- Thermal
 - Motor thermistor.
 - Motor overload.
 - Bypass contactor overload.
 - Heat sink temperature.
- Communication
 - Network comms.
 - Starter comms.
- External
 - Input trip.
- Starter
 - Individually short-circuited SCR.
 - Battery/clock.

2.1.2 Type Code

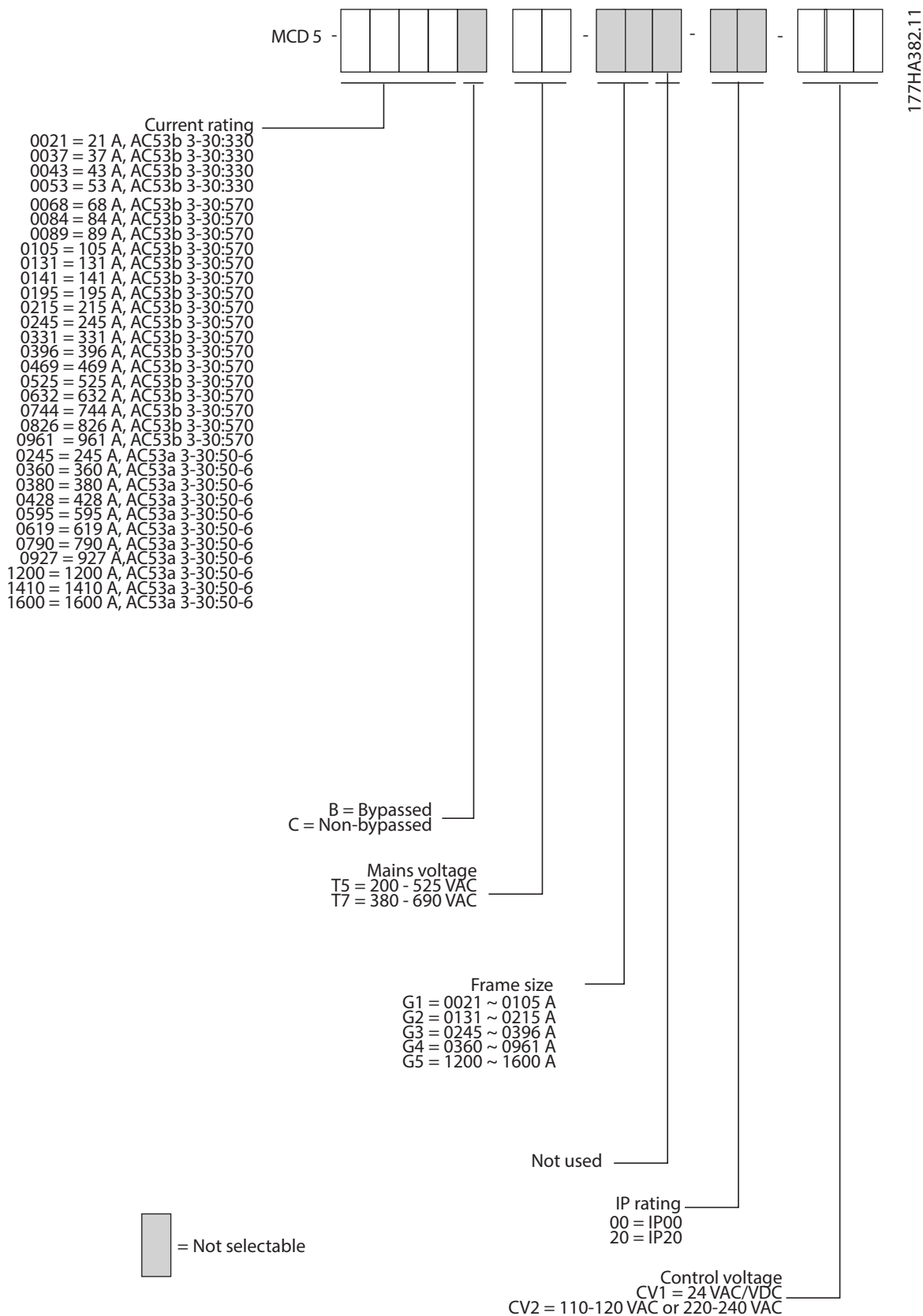
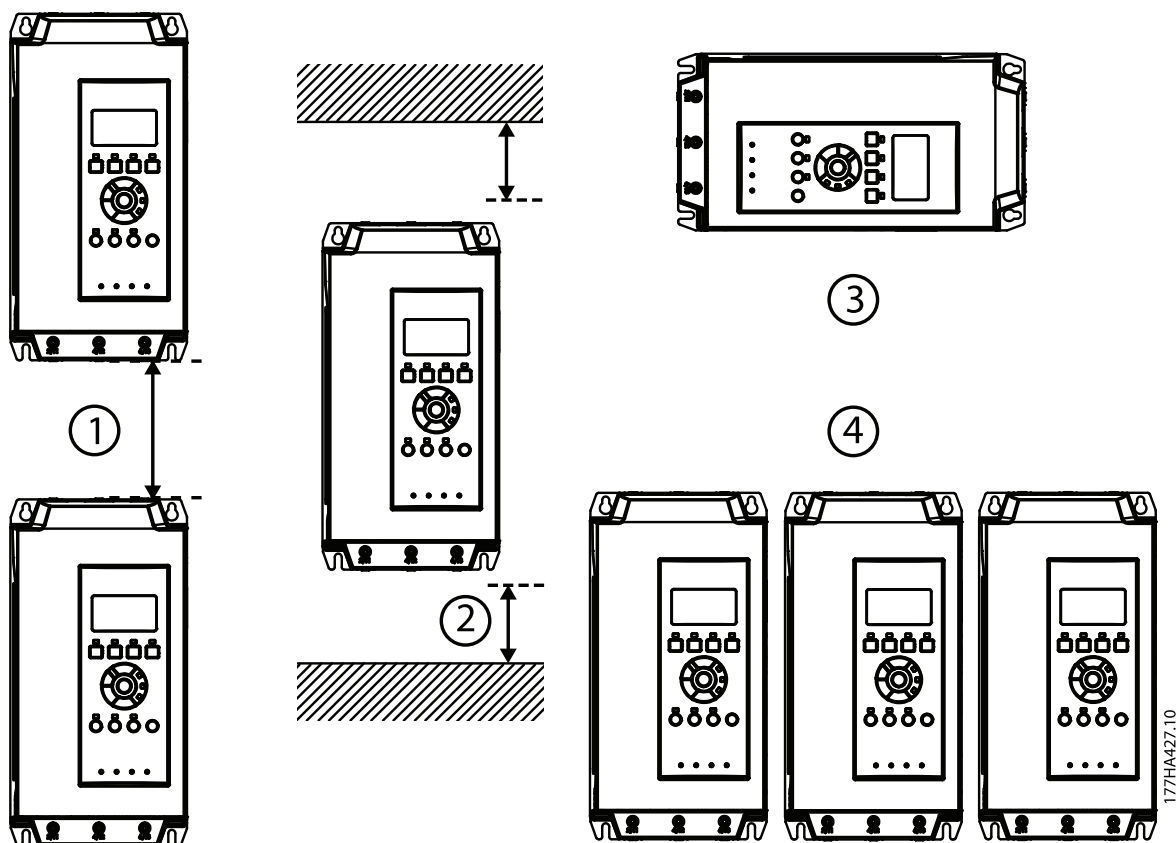

Illustration 2.1 Type Code Ordering Form

3 Installation

3.1 Mechanical Installation

3



1	MCD5-0021B to MCD5-0215B: Allow 100 mm (3.94 inches) between the soft starters. MCD5-0245B to MCD5-0961B: Allow 200 mm (7.88 inches) between the soft starters. MCD5-0245C: Allow 100 mm (3.94 inches) between the soft starters. MCD5-0360C to MCD5-1600C: Allow 200 mm (7.88 inches) between the soft starters.
2	MCD5-0021B to MCD5-0215B: Allow 50 mm (1.97 inches) between the soft starter and solid surfaces. MCD5-0245B to MCD5-0961B: Allow 200 mm (7.88 inches) between soft starters. MCD5-0245C: Allow 100 mm (3.94 inches) between the soft starter and solid surfaces. MCD5-0360C to MCD5-1600C: Allow 200 mm (7.88 inches) between the soft starter and solid surfaces.
3	It is possible to mount the soft starter on its side. Derate the soft starter rated current by 15%.
4	If mounted without communication modules, soft starters may be mounted side-by-side with no clearance.

Illustration 3.1 Clearances and Derating Values at Installation

3.2 Dimensions and Weights

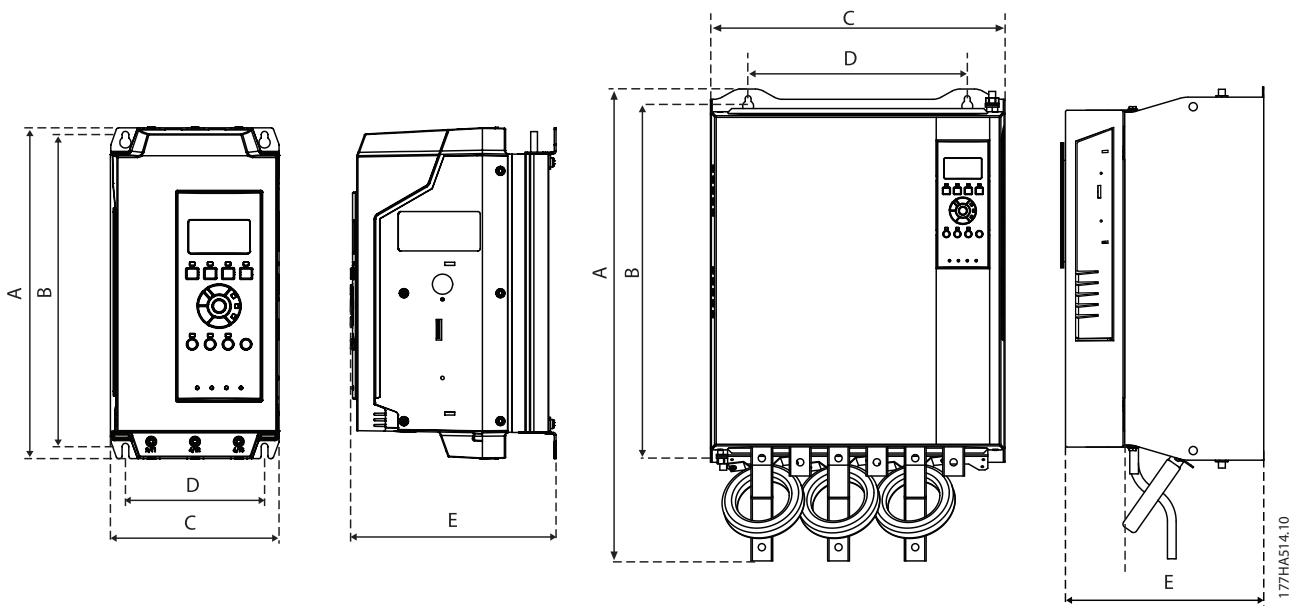

3

Model	A [mm] (in)	B [mm] (in)	C [mm] (in)	D [mm] (in)	E [mm] (in)	Weight [kg] (lbs)
MCD5-0021B						4.2
MCD5-0037B					183	4.2
MCD5-0043B					(7.2)	(9.3)
MCD5-0053B						
MCD5-0068B	295	278	150	124		4.5
	(11.6)	(10.9)	(5.9)	(4.9)		(9.9)
MCD5-0084B					213	4.9
MCD5-0089B					(8.14)	(10.8)
MCD5-0105B						
MCD5-0131B						14.9
MCD5-0141B	438	380	275	248	250	14.9
MCD5-0195B	(17.2)	(15.0)	(10.8)	(9.8)	(9.8)	(32.8)
MCD5-0215B						
MCD5-0245B						26 (57.2)
MCD5-0331B	440	392	424	376	296	30.2
MCD5-0396B	(17.3)	(15.4)	(16.7)	(14.8)	(11.7)	(66.6)
MCD5-0469B						49.5
MCD5-0525B						(109.1)
MCD5-0632B	640	600	433	320	295	60.0
MCD5-0744B	(25.2)	(23.6)	(17.0)	(12.6)	(11.6)	(132.3)
MCD5-0826B						
MCD5-0961B						
MCD5-0245C	460	400	390	320	279	23.9
	(18.1)	(15.0)	(15.4)	(12.6)	(11.0)	(52.7)
MCD5-0360C						35
MCD5-0380C						(77.2)
MCD5-0428C						
MCD5-0595C	689	522	430	320	300	45
MCD5-0619C	(27.1)	(20.5)	(16.9)	(12.6)	(11.8)	(99.2)
MCD5-0790C						
MCD5-0927C						

Model	A [mm] (in)	B [mm] (in)	C [mm] (in)	D [mm] (in)	E [mm] (in)	Weight [kg] (lbs)
MCD5-1200C	856	727	585	500	364	120
MCD5-1410C	(33.7)	(28.6)	(23.0)	(19.7)	(14.3)	(264.6)
MCD5-1600C						

3

Illustration 3.2 Dimensions and Weights

4 Electrical Installation

4.1 Control Wiring

4.1.1 Ways to Control the Soft Starter

Control the soft starter in 3 ways:

- Pressing the keys on the LCP.
- Via remote inputs.
- Via a serial communication link.

The MCD 500 always responds to a local start or stop command (via the [Hand On] and [Off] keys on the LCP). Pressing the [Auto On] key selects remote control (the soft starter accepts commands from the remote inputs). In remote mode, the Auto On LED is on. In local mode, the Hand On LED is on if the soft starter starts or runs. The Off LED is on if the soft starter is stopped or stops.

4.1.2 Control Terminals

Control terminations use 2.5 mm² plug-in terminal blocks. Different models require control voltage to different terminals:

- CV1 (24 V AC/V DC): A5, A6.
- CV2 (110–120 V AC): A5, A6.
- CV2 (220–240 V AC): A4, A6.

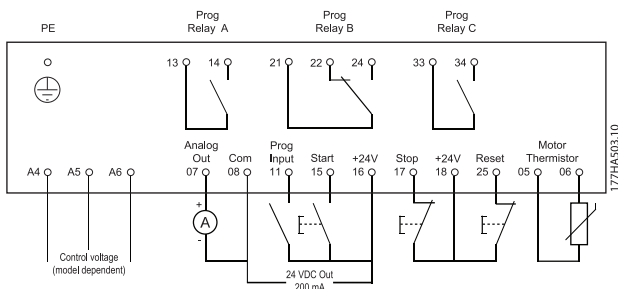

Illustration 4.1 Wiring to Control Terminals

NOTICE

Do not short terminals 05 and 06 without using a thermistor.

All control terminals and relay terminals comply with SELV (Safety Extra Low Voltage). This protection does not apply to grounded delta leg above 400 V.

To maintain SELV, all connections made to the control terminals must be PELV (for example thermistor must be reinforced/double insulated from motor).

NOTICE

SELV offers protection by way of extra low voltage. Protection against electric shock is ensured when the electrical supply itself is of the SELV type and the installation follows local/national regulations on SELV supplies.

NOTICE

Galvanic (ensured) isolation is obtained by fulfilling requirements for higher isolation and by providing the relevant creepages/clearance distances. These requirements are described in the IEC 61140 standard. The components that make up the electrical isolation also comply with the requirements for higher isolation and the relevant test as described in IEC 61140.

4.1.3 Remote Inputs

The soft starter has 3 fixed inputs for remote control. Control these inputs by contacts rated for low voltage, low current operation (gold flash or similar).

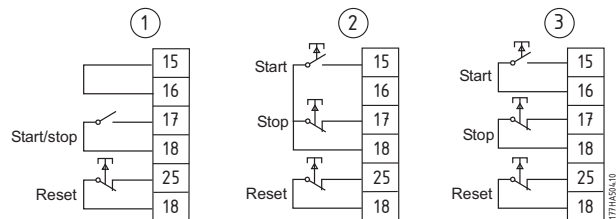

1	2-wire control
2	3-wire control
3	4-wire control

Illustration 4.2 2-, 3-, and 4-wire Control

The reset input can be normally open or normally closed. To select the configuration, use *parameter 3-8 Remote Reset Logic*.

CAUTION

Do not apply voltage to the control input terminals. These terminals are active 24 V DC inputs and must be controlled with potential-free contacts. Segregate cables to the control inputs from mains voltage and motor cabling.

4.1.4 Serial Communication

Control via the serial communication network is always enabled in local control mode and can be enabled or disabled in remote control mode (see *parameter 3-2 Comms in Remote*). Control via the serial communication network requires an optional communication module.

4

4.1.5 Ground Terminal

Ground terminals are located at the back of the soft starter.

- MCD5-0021B to MCD5-0105B have 1 terminal on the input side (top).
- MCD5-0131B to MCD5-0961B and MCD5-0245C to MCD5-1600C have 2 terminals, 1 on the input side (top), and 1 on the output side (bottom).

4.1.6 Power Terminations

NOTICE

For personnel safety, snap-off tabs protect the power terminals on models up to MCD5-0105B. When using large cables, it may be necessary to break off these tabs.

NOTICE

Some units use aluminium busbars. When connecting power terminations, clean the surface contact area thoroughly (using an emery or stainless steel brush), and use an appropriate jointing compound to prevent corrosion.

Use only copper stranded or solid conductors, rated for 75 °C or higher.

 <p>Cable size: 6–50 mm² (AWG 10–1/0) Torque: 4 Nm (2.9 ft-lb)</p>	 <p>14 mm (0.55 inch)</p>	 <p>Torx T20 x 150 Flat 7 mm x 150</p>
MCD5-0021B to MCD5-0105B		
 <p>8.5 Nm (6.3 ft-lb)</p>	 <p>8.5 Nm (6.3 ft-lb)</p>	 <p>38 Nm (28 ft-lb)</p>
MCD5-0131B	MCD5-0141B to MCD5-0215B	MCD5-0245B
 <p>38 Nm (28 ft-lb)</p>	 <p>38 Nm (28 ft-lb)</p>	 <p>17 Nm (12.5 ft-lb)</p>
MCD5-0331B to MCD5-0396B	MCD5-0469B to MCD5-0961B	MCD5-0245C
 <p>38 Nm (28.5 ft-lb)</p>	 <p>58 Nm (42.7 ft-lb)</p>	
MCD5-0360C to MCD5-0927C	MCD5-1200C to MCD5-1600C	

Table 4.1 Measurements and Torques for Power Terminations

4.2 Power Input and Output Configurations

4.2.1 Internally Bypassed Models (MCD5-0021B to MCD5-0961B)

Models MCD5-0021B to MCD5-0215B have power inputs at the top of the unit and outputs at the bottom of the unit.

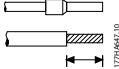
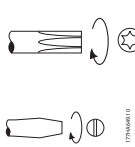
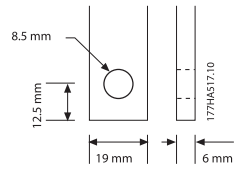
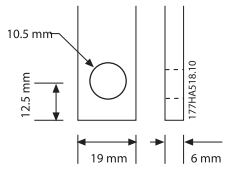
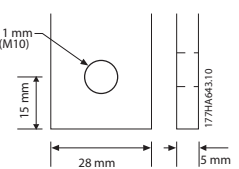
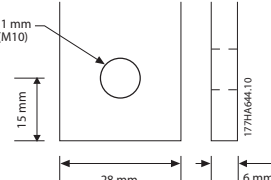
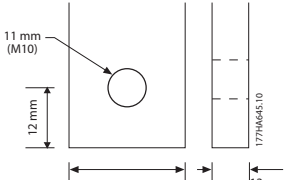
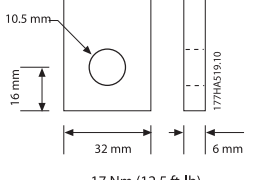
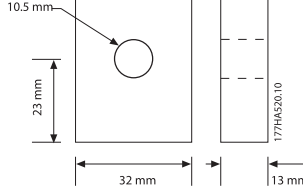
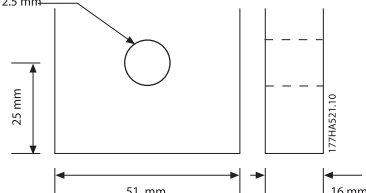
Internally bypassed models MCD5-0245B to MCD5-0396B have output busbars at the bottom of the unit and input busbars at both the top and bottom. The AC supply can be connected *top-in, bottom-out* or *bottom-in, bottom-out*.

Internally bypassed models MCD5-0469B to MCD5-0961B have input and output busbars at the top and bottom of the unit. The AC supply can be connected:

- Top-in/bottom-out.
- Top-in/top-out.
- Bottom-in/bottom-out.
- Bottom-in/top-out.

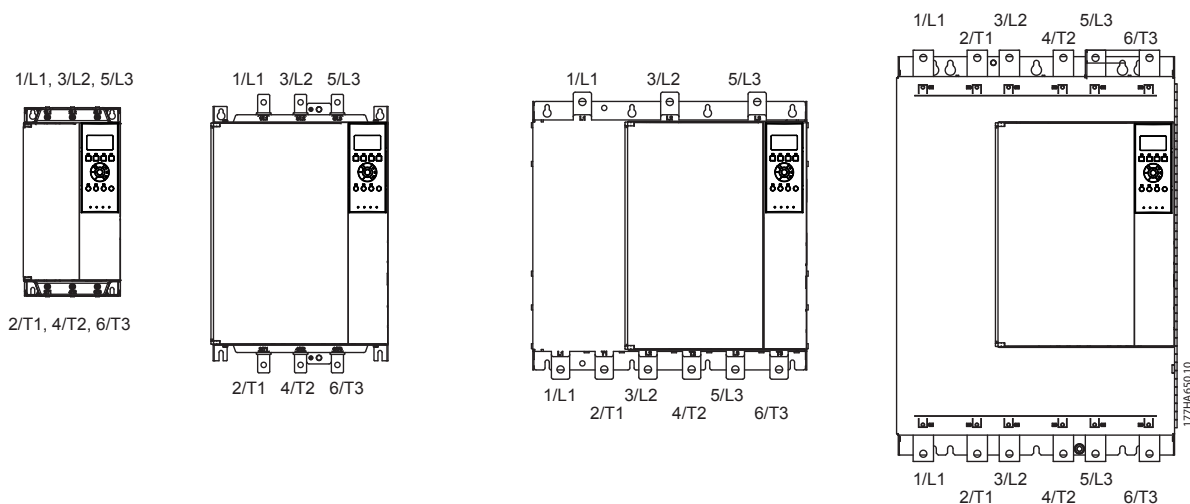

Illustration 4.3 Internally Bypassed Models, MCD5-0021B to MCD5-0105B, MCD5-0131B to MCD5-0215B, MCD5-0245B to MCD5-0396B, MCD5-0469B to MCD5-0961B

4.2.2 MCD5-0245C

MCD5-0245C has dedicated bypass terminals at the bottom of the unit. The bypass terminals are:

- T1B
- T2B
- T3B

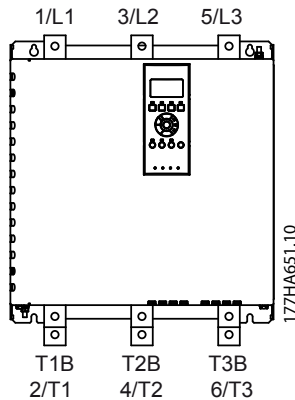

Illustration 4.4 Bypass Terminals on MCD5-0245C

4.2.3 MCD5-0360C to MCD5-1600C

MCD5-0360C to MCD5-1600C have dedicated bypass terminals on the input busbars. The bypass terminals are:

- L1B
- L2B
- L3B

The busbars on non-bypassed models MCD5-0360C to MCD5-1600C can be adjusted for top or bottom input and output as required. See *chapter 12 Busbar Adjustment Procedure (MCD5-0360C to MCD5-1600C)* for step-by-step instructions. The soft starters are manufactured top-in/ bottom-out.

NOTICE

For models MCD5-0360C to MCD5-1600C to be UL-compliant, mount them *top-in, bottom-out, or top-out, bottom-in*. See *chapter 11.1 UL Compliant Installation* for more information.

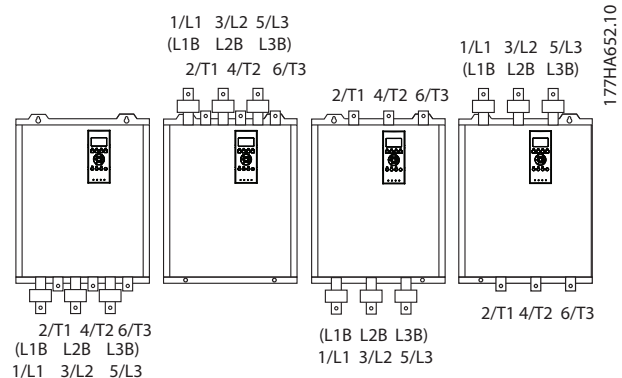

Illustration 4.5 Location of Bypass Terminals, MCD5-0360C to MCD5-1600C

4.3 Motor Connection

MCD 500 soft starters can be connected to the motor in-line or inside delta (also called 3-wire and 6-wire connection). When connecting in inside delta, enter the motor full load current (FLC) for *parameter 1-1 Motor Full Load Current*. The MCD 500 automatically calculates inside delta current based on this data. *Parameter 15-7 Motor Connection* is set to *Auto Detect* as default and can be set to force the soft starter in inside delta or in-line.

4.3.1 Testing the Installation

The MCD 500 can be connected to a small motor for testing. During this test, the control input and relay output protection settings can be tested. This test mode is not suitable for testing soft starting or soft stopping performance.

The minimum FLC of the test motor is 2% of the minimum FLC of the soft starter (see *chapter 4.5 Minimum and Maximum Current Settings*).

NOTICE

When testing the soft starter with a small motor, set *parameter 1-1 Motor FLC* to the minimum allowable value.

Models which are internally bypassed do not require an external bypass contactor.

4.3.2 In-line Installation

4.3.2.1 Internally Bypassed

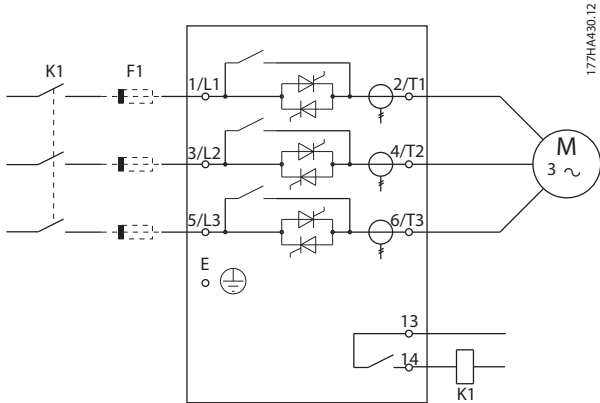

K1	Main contactor (optional)
F1	Semiconductor fuses (optional)

Illustration 4.6 In-line Installation, Internally Bypassed

4.3.2.2 Non-bypassed

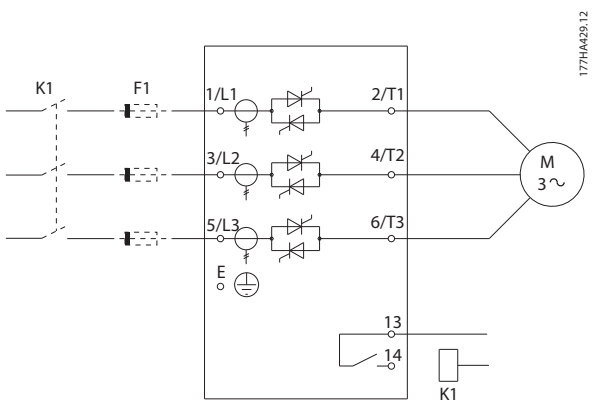

K1	Main contactor (optional)
F1	Semiconductor fuses (optional)

Illustration 4.7 In-line Installation, Non-bypassed

4.3.2.3 Externally Bypassed

Non-bypassed models have dedicated bypass terminals, which allow the soft starter to continue providing protection and monitoring functions even when bypassed via an external contactor. Connect the bypass contactor to the bypass terminals and control it by a programmable output configured to Run (see parameters 4-1 to 4-9).

NOTICE

The bypass terminals on MCD5-0245C are:

- T1B
- T2B
- T3B

The bypass terminals on MCD5-0360C to MCD5-1600C are:

- L1B
- L2B
- L3B

If necessary, the fuses can be installed on the input side.

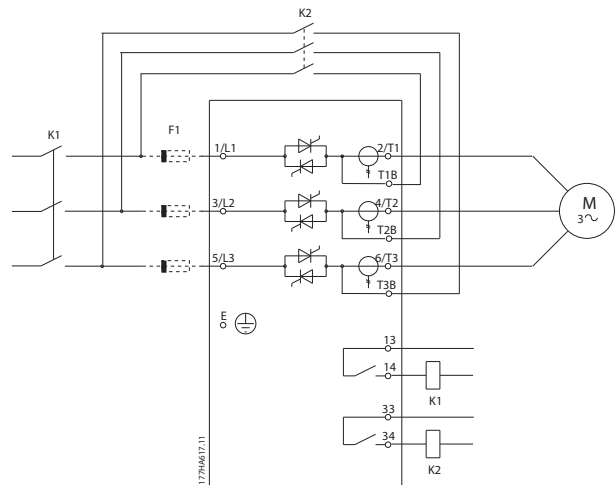

K1	Main contactor
K2	Bypass contactor (external)
F1	Semiconductor fuses (optional)

Illustration 4.8 In-line Installation, Externally Bypassed, MCD5-0245C

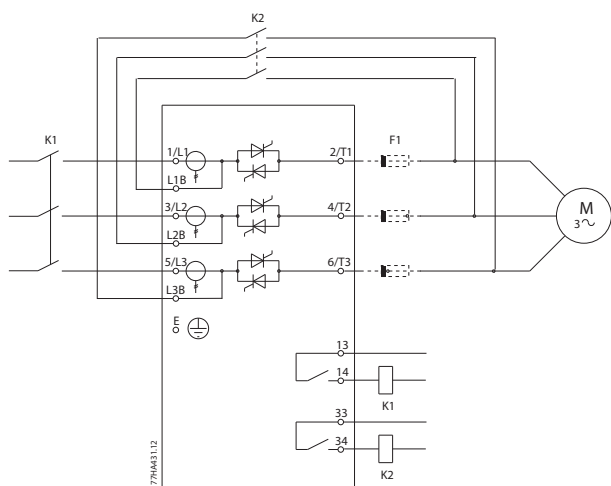

K1	Main contactor
K2	Bypass contactor (external)
F1	Semiconductor fuses (optional)

Illustration 4.9 In-line Installation, Externally Bypassed, MCD5-0360Cto MCD5-1600C

4.3.3 Inside Delta Installation

CAUTION

When connecting the MCD 500 in inside delta configuration, always install a main contactor or shunt trip circuit breaker.

NOTICE

When connecting in inside delta, enter the motor full load current (FLC) for *parameter 1-1 Motor FLC*. The MCD 500 automatically calculates inside delta currents based on this data. *Parameter 15-7 Motor Connection* is set to *Auto detect* as default and can be set to force the soft starter in inside delta or in-line.

4.3.3.1 Internally Bypassed

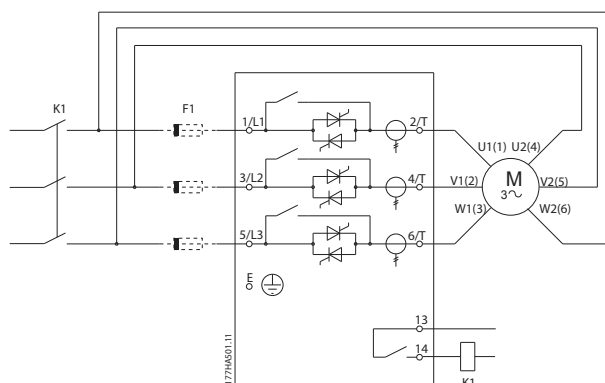

K1	Main contactor
F1	Semiconductor fuses (optional)

Illustration 4.10 Inside Delta Installation, Internally Bypassed

4.3.3.2 Non-bypassed

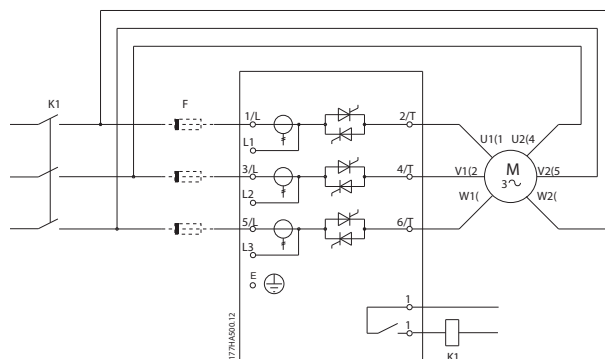

K1	Main contactor
F1	Semiconductor fuses (optional)

Illustration 4.11 Inside Delta Installation, Non-bypassed

4.3.3.3 Externally Bypassed

Non-bypassed models have dedicated bypass terminals, which allow the soft starter to continue providing protection and monitoring functions even when bypassed via an external bypass contactor. Connect the bypass contactor to the bypass terminals and control the contactor by a programmable output configured to *Run* (see parameters 4-1 to 4-9).

NOTICE

The bypass terminals on MCD5-0245C are:

- T1B
- T2B
- T3B

The bypass terminals on MCD5-0360C to MCD5-1600C are:

- L1B
- L2B
- L3B

If necessary, the fuses can be installed on the input side.

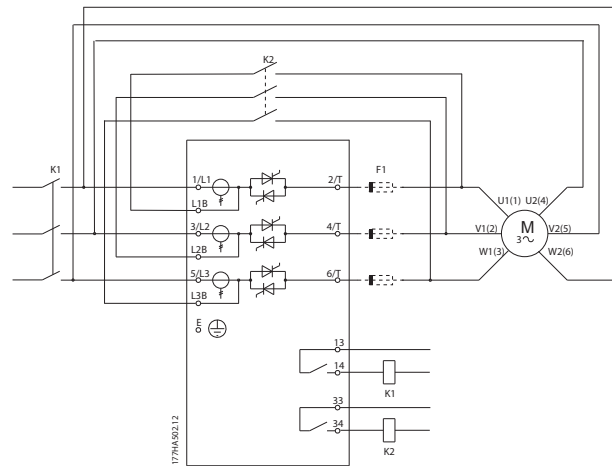

K1	Main contactor
K2	Bypass contactor (external)
F1	Semiconductor fuses (optional)

Illustration 4.13 Inside Delta Installation, Externally Bypassed, MCD5-0360C to MCD5-1600C

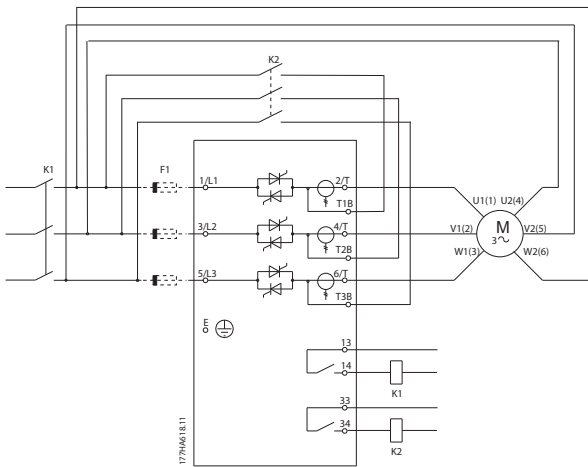

K1	Main contactor
K2	Bypass contactor (external)
F1	Semiconductor fuses (optional)

Illustration 4.12 Inside Delta Installation, Externally Bypassed, MCD5-0245C

4.4 Current Ratings

Contact the local supplier for ratings under operating conditions not covered by these ratings charts.

All ratings are calculated at an altitude of 1000 m and ambient temperature of 40 °C.

4.4.1 In-line Connection (Bypassed)

NOTICE

Models MCD5-0021B to MCD5-0961B are internally bypassed. Models MCD5-0245C to MCD5-1600C require an external bypass contactor.

Type code	Ampere rating		
	AC-53b 3-30:330 [A]	AC-53b 4-20:340 [A]	AC-53b 4.5-30:330 [A]
MCD5-0021B	21	17	15
MCD5-0037B	37	31	26
MCD5-0043B	43	37	30
MCD5-0053B	53	46	37
	AC-53b 3-30:570 [A]	AC-53b 4-20:580 [A]	AC-53b 4.5-30:570 [A]
MCD5-0068B	68	55	47
MCD5-0084B	84	69	58
MCD5-0089B	89	74	61
MCD5-0105B	105	95	78
MCD5-0131B	131	106	90
MCD5-0141B	141	121	97
MCD5-0195B	195	160	134
MCD5-0215B	215	178	148
MCD5-0245B	245	194	169
MCD5-0245C	255	201	176
MCD5-0331B	331	266	229
MCD5-0360C	360	310	263
MCD5-0380C	380	359	299
MCD5-0396B	396	318	273
MCD5-0428C	430	368	309
MCD5-0469B	496	383	326
MCD5-0525B	525	425	364
MCD5-0595C	620	540	434
MCD5-0619C	650	561	455
MCD5-0632B	632	512	438
MCD5-0790C	790	714	579
MCD5-0744B	744	606	516
MCD5-0826B	826	684	571
MCD5-0927C	930	829	661
MCD5-0961B	961	796	664
MCD5-1200C	1200	1200	1071
MCD5-1410C	1410	1319	1114
MCD5-1600C	1600	1600	1353

Table 4.2 Internally Bypassed Models

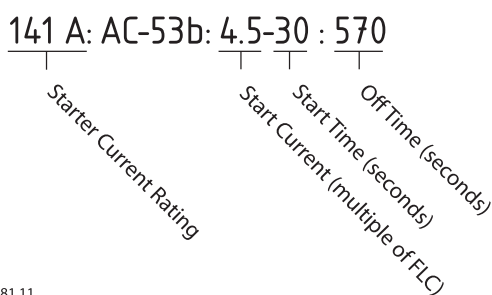

177HA281.11

Illustration 4.14 AC-53 Rating for Bypassed Operation

4

All ratings are calculated at an altitude of 1000 m and ambient temperature of 40 °C.

4.4.2 In-line Connection (Non-bypassed/Continuous)

Type code	Ampere ratings		
	AC-53a 3-30:50-6	AC-53a 4-20:50-6	AC-53a 4.5-30:50-6
MCD5-0245C	245 A	195 A	171 A
MCD5-0360C	360 A	303 A	259 A
MCD5-0380C	380 A	348 A	292 A
MCD5-0428C	428 A	355 A	300 A
MCD5-0595C	595 A	515 A	419 A
MCD5-0619C	619 A	532 A	437 A
MCD5-0790C	790 A	694 A	567 A
MCD5-0927C	927 A	800 A	644 A
MCD5-1200C	1200 A	1135 A	983 A
MCD5-1410C	1410 A	1187 A	1023 A
MCD5-1600C	1600 A	1433 A	1227 A

Table 4.3 Non-bypassed Models

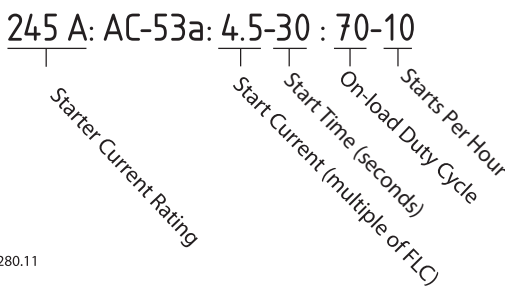

177HA280.11

Illustration 4.15 AC-53 Rating for Continuous Operation

All ratings are calculated at an altitude of 1000 m and ambient temperature of 40 °C.

Contact a local supplier for ratings under operating conditions not covered by these ratings charts.

4.4.3 Inside Delta Connection (Bypassed)

NOTICE

Models MCD5-0021B to MCD5-0961B are internally bypassed. Models MCD5-0245C to MCD5-1600C require an external bypass contactor.

Type code	Ampere ratings		
	AC-53b 3-30:330 [A]	AC-53b 4.20-:340 [A]	AC-53b 4.5-30:330 [A]
MCD5-0021B	32	26	22
MCD5-0037B	56	47	39
MCD5-0043B	65	56	45
MCD5-0053B	80	69	55
	AC-53b 3-30:570 [A]	AC-53b 4-20:580 [A]	AC-53b 4.5-30:570 [A]
MCD5-0068B	102	83	71
MCD5-0084B	126	104	87
MCD5-0089B	134	112	92
MCD5-0105B	158	143	117
MCD5-0131B	197	159	136
MCD5-0141B	212	181	146
MCD5-0195B	293	241	201
MCD5-0215B	323	268	223
MCD5-0245B	368	291	254
MCD5-0245C	383	302	264
MCD5-0331B	497	400	343
MCD5-0360C	540	465	395
MCD5-0380C	570	539	449
MCD5-0396B	594	478	410
MCD5-0428C	645	552	463
MCD5-0469B	704	575	490
MCD5-0525B	787	637	546
MCD5-0595C	930	810	651
MCD5-0619C	975	842	683
MCD5-0632B	948	768	658
MCD5-0790C	1185	1072	869
MCD5-0744B	1116	910	774
MCD5-0826B	1239	1026	857
MCD5-0927C	1395	1244	992
MCD5-0961B	1441	1194	997
MCD5-1200C	1800	1800	1607
MCD5-1410C	2115	1979	1671
MCD5-1600C	2400	2400	2030

Table 4.4 Bypassed Models

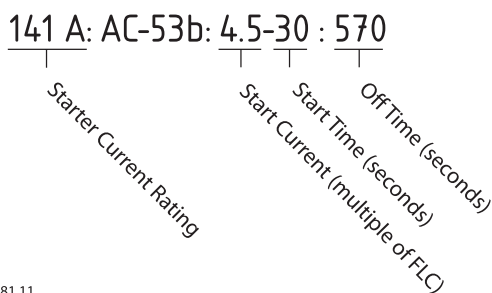

177HA281.11

Illustration 4.16 AC-53 Rating for Bypassed Operation

4

All ratings are calculated at an altitude of 1000 m and ambient temperature of 40 °C.

4.4.4 Inside Delta Connection (Non-bypassed/Continuous)

Type code	Ampere ratings		
	AC-53a 3-30:50-6	AC-53a 4-20:50-6	AC-53a 4.5-30:50-6
MCD5-0245C	368 A	293 A	257 A
MCD5-0360C	540 A	455 A	389 A
MCD5-0380C	570 A	522 A	438 A
MCD5-0428C	643 A	533 A	451 A
MCD5-0595C	893 A	773 A	629 A
MCD5-0619C	929 A	798 A	656 A
MCD5-0790C	1185 A	1042 A	851 A
MCD5-0927C	1391 A	1200 A	966 A
MCD5-1200C	1800 A	1702 A	1474 A
MCD5-1410C	2115 A	1780 A	1535 A
MCD5-1600C	2400 A	2149 A	1841 A

Table 4.5 Non-bypassed Models

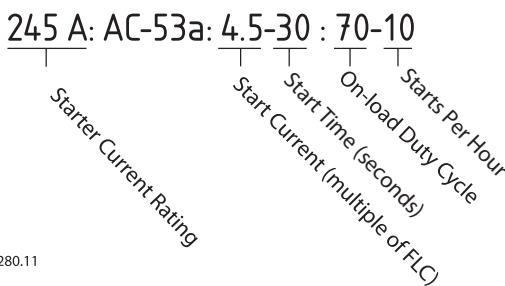

177HA280.11

Illustration 4.17 AC-53 Rating for Continuous Operation

All ratings are calculated at an altitude of 1000 m and ambient temperature of 40 °C.

Contact a local supplier for ratings under operating conditions not covered by these ratings charts.

4.5 Minimum and Maximum Current Settings

The minimum and maximum full load current settings depend on the model:

Model	In-line connection		Inside delta connection	
	Minimum [A]	Maximum [A]	Minimum [A]	Maximum [A]
MCD5-0021B	5	23	7	34
MCD5-0037B	9	43	13	64
MCD5-0043B	10	50	15	75
MCD5-0053B	11	53	16	79
MCD5-0068B	15	76	23	114
MCD5-0084B	19	97	29	145
MCD5-0089B	20	100	30	150
MCD5-0105B	21	105	32	157
MCD5-0131B	29	145	44	217
MCD5-0141B	34	170	51	255
MCD5-0195B	40	200	60	300
MCD5-0215B	44	220	66	330
MCD5-0331B	70	350	70	525
MCD5-0396B	85	425	85	638
MCD5-0469B	100	500	100	750
MCD5-0525B	116	580	116	870
MCD5-0632B	140	700	140	1050
MCD5-0744B	164	820	164	1230
MCD5-0825B	184	920	184	1380
MCD5-0961B	200	1000	200	1500
MCD5-0245C	51	255	77	382
MCD5-0360C	72	360	108	540
MCD5-0380C	76	380	114	570
MCD5-0428C	86	430	129	645
MCD5-0595C	124	620	186	930
MCD5-0619C	130	650	195	975
MCD5-0790C	158	790	237	1185
MCD5-0927C	186	930	279	1395
MCD5-1200C	240	1200	360	1800
MCD5-1410C	282	1410	423	2115
MCD5-1600C	320	1600	480	2400

Table 4.6 Minimum and Maximum Full Load Current

4.6 Bypass Contactor

Some MCD 500 soft starters are internally bypassed and do not require an external bypass contactor.

Non-bypassed soft starters may be installed with an external bypass contactor. Select a contactor with an AC1 rating greater than or equal to the full load current rating of the connected motor.

4.7 Main Contactor

A main contactor must be installed if the MCD 500 is connected to the motor in inside delta format and is optional for in-line connection. Select a contactor with an AC3 rating greater than or equal to the full load current rating of the connected motor.

4.8 Circuit Breaker

A shunt trip circuit breaker may be used instead of a main contactor to isolate the motor circuit in the event of a soft starter trip. The shunt trip mechanism must be powered from the supply side of the circuit breaker or from a separate control supply.

4.9 Power Factor Correction

CAUTION

EQUIPMENT DAMAGE

Connect power factor correction capacitors to the input side of the soft starter. Connecting power factor correction capacitors to the output side damages the soft starter.

If power factor correction is used, use a dedicated contactor to switch in the capacitors.

4.10 Fuses

4.10.1 Power Supply Fuses

Semiconductor fuses can be used for Type 2 coordination (according to the IEC 60947-4-2 standard). They reduce the risk of damage to SCRs from transient overload currents.

HRC fuses (such as Ferraz AJT fuses) can be used for Type 1 coordination according to the IEC 60947-4-2 standard.

CAUTION

Adaptive control controls the speed profile of the motor within the programmed time limit. This control may result in a higher level of current than traditional control methods.

For applications using adaptive control to soft stop the motor with stop times greater than 30 s, select motor branch protection as follows:

- Standard HRC mains fuses: Minimum 150% motor full load current.
- Motor rated mains fuses: Minimum rating 100/150% motor full load current.
- Motor control circuit breaker minimum long time setting: 150% motor full load current.
- Motor control circuit breaker minimum short time setting: 400% motor full load current for 30 s.

Fuse recommendations are calculated for 40 °C, up to 1000 m.

NOTICE

Fuse selection is based on a 400% FLC start for 20 s with:

- Standard published starts per hour.
- Duty cycle.
- 40 °C ambient temperature.
- Up to 1000 m altitude.

For installations operating outside these conditions, consult a local Danfoss supplier.

Table 4.7 to Table 4.12 contain recommendations only. Always consult a local supplier to confirm the selection for a particular application.

4.10.2 Bussmann Fuses

Model	SCR I ² t (A ² s)	Supply voltage (≤440 V AC)	Supply voltage (≤575 V AC)	Supply voltage (≤690 V AC)
MCD5-0021B	1150	170M1314	170M1314	170M1314
MCD5-0037B	8000	170M1316	170M1316	170M1316
MCD5-0043B	10500	170M1318	170M1318	170M1318
MCD5-0053B	15000	170M1318	170M1318	170M1318
MCD5-0068B	15000	170M1319	170M1319	170M1318
MCD5-0084B	512000	170M1321	170M1321	170M1319
MCD5-0089B	80000	170M1321	170M1321	170M1321
MCD5-0105B	125000	170M1321	170M1321	170M1321
MCD5-0131B	125000	170M1321	170M1321	170M1321
MCD5-0141B	320000	170M2621	170M2621	170M2621
MCD5-0195B	320000	170M2621	170M2621	170M2621
MCD5-0215B	320000	170M2621	170M2621	170M2621
MCD5-0245B	320000	170M2621	170M2621	170M2621
MCD5-0331B	202000	170M5011	170M5011	-
MCD5-0396B	320000	170M6011	-	-
MCD5-0469B	320000	170M6008 ¹⁾	-	-
MCD5-0525B	781000	170M6013	170M6013	170M6013
MCD5-0632B	781000	170M5015	170M5015	-
MCD5-0744B	1200000	170M5017	170M6017	-
MCD5-0826B	2530000	170M6017	170M6017	-
MCD5-0961B	2530000	170M6018	170M6013 ¹⁾	-
MCD5-0245C	320000	170M2621	170M2621	170M2621
MCD5-0360C	320000	170M6010	170M6010	170M6010
MCD5-0380C	320000	170M6011	170M6011	-
MCD5-0428C	320000	170M6011	170M6011	-
MCD5-0595C	1200000	170M6015	170M6015	170M6014
MCD5-0619C	1200000	170M6015	170M6015	170M6014
MCD5-0790C	2530000	170M6017	170M6017	170M6016
MCD5-0927C	4500000	170M6019	170M6019	170M6019
MCD5-1200C	4500000	170M6021	-	-
MCD5-1410C	6480000	-	-	-
MCD5-1600C	12500000	170M6019 ¹⁾	-	-

Table 4.7 Square Body (170M)

1) Two fuses connected in parallel are required per phase.

Model	SCR I ² t (A ² s)	Supply voltage (<440 V AC)	Supply voltage (<575 V AC)	Supply voltage (<690 V AC)
MCD5-0021B	1150	63FE	63FE	63FE
MCD5-0037B	8000	120FEE	120FEE	120FEE
MCD5-0043B	10500	120FEE	120FEE	120FEE
MCD5-0053B	15000	200FEE	200FEE	200FEE
MCD5-0068B	15000	200FEE	200FEE	200FEE
MCD5-0084B	512000	200FEE	200FEE	200FEE
MCD5-0089B	80000	280FM	280FM	280FM
MCD5-0105B	125000	280FM	280FM	280FM
MCD5-0131B	125000	280FM	280FM	280FM
MCD5-0141B	320000	450FMM	450FMM	450FMM
MCD5-0195B	320000	450FMM	450FMM	450FMM
MCD5-0215B	320000	450FMM	450FMM	450FMM
MCD5-0245B	320000	450FMM	450FMM	450FMM
MCD5-0331B	202000	315FM ¹⁾	-	-
MCD5-0396B	320000	400FMM ¹⁾	-	-
MCD5-0469B	320000	450FMM ¹⁾	-	-
MCD5-0525B	781000	500FMM ¹⁾	500FMM ¹⁾	500FMM ¹⁾
MCD5-0632B	781000	630FMM ¹⁾	-	-
MCD5-0744B	1200000	-	-	-
MCD5-0826B	2530000	-	-	-
MCD5-0961B	2530000	-	-	-
MCD5-0245C	320000	450FMM	450FMM	450FMM
MCD5-0360C	320000	-	-	-
MCD5-0380C	320000	400FMM ¹⁾	400FMM	400FMM ¹⁾
MCD5-0428C	320000	-	-	-
MCD5-0595C	1200000	630FMM ¹⁾	630FMM ¹⁾	-
MCD5-0619C	1200000	630FMM ¹⁾	630FMM ¹⁾	-
MCD5-0790C	2530000	-	-	-
MCD5-0927C	4500000	-	-	-
MCD5-1200C	4500000	-	-	-
MCD5-1410C	6480000	-	-	-
MCD5-1600C	12500000	-	-	-

Table 4.8 British Style (BS88)

1) Two fuses connected in parallel are required per phase.

4.10.3 Ferraz Fuses

Model	SCR I ² t (A ² s)	Supply voltage (<440 V AC)	Supply voltage (<575 V AC)	Supply voltage (<690 V AC)		
MCD5-0021B	1150	HSJ40 ¹⁾	HSJ40 ¹⁾	Not applicable		
MCD5-0037B	8000	HSJ80 ¹⁾	HSJ80 ¹⁾			
MCD5-0043B	10500	HSJ90 ¹⁾	HSJ90 ¹⁾			
MCD5-0053B	15000	HSJ110 ¹⁾	HSJ110 ¹⁾			
MCD5-0068B	15000	HSJ125 ¹⁾	HSJ125 ¹⁾			
MCD5-0084B	51200	HSJ175	HSJ175 ¹⁾			
MCD5-0089B	80000	HSJ175	HSJ175			
MCD5-0105B	125000	HSJ225	HSJ225			
MCD5-0131B	125000	HSJ250	HSJ250 ¹⁾			
MCD5-0141B	320000	HSJ300	HSJ300			
MCD5-0195B	320000	HSJ350	HSJ350			
MCD5-0215B	320000	HSJ400 ¹⁾	HSJ400 ¹⁾			
MCD5-0245B	320000	HSJ450 ¹⁾	HSJ450 ¹⁾			
MCD5-0331B	202000	HSJ500 ¹⁾	Not applicable			
MCD5-0396B	320000	Not applicable				
MCD5-0469B	320000					
MCD5-0525B	781000					
MCD5-0632B	781000					
MCD5-0744B	1200000					
MCD5-0826B	2530000					
MCD5-0961B	2530000					
MCD5-0245C	320000				HSJ450 ¹⁾	HSJ450 ¹⁾
MCD5-0360C	320000				Not applicable	
MCD5-0380C	320000					
MCD5-0428C	320000					
MCD5-0595C	1200000					
MCD5-0619C	1200000					
MCD5-0790C	2530000					
MCD5-0927C	4500000					
MCD5-1200C	4500000					
MCD5-1410C	6480000					
MCD5-1600C	12500000					

Table 4.9 HSJ

1) 2 series connected fuses required per phase.

Model	SCR I ² t (A ² s)	Supply voltage (<440 V AC)	Supply voltage (<575 V AC)	Supply voltage (<690 V AC)
MCD5-0021B	1150	A070URD30XXX0063	A070URD30XXX0063	-
MCD5-0037B	8000	A070URD30XXX0125	A070URD30XXX0125	A070URD30XXX0125
MCD5-0043B	10500	A070URD30XXX0125	A070URD30XXX0125	A070URD30XXX0125
MCD5-0053B	15000	A070URD30XXX0125	A070URD30XXX0125	A070URD30XXX0125
MCD5-0068B	15000	A070URD30XXX0160	A070URD30XXX0160	A070URD30XXX0160
MCD5-0084B	51200	A070URD30XXX0200	A070URD30XXX0200	A070URD30XXX0200
MCD5-0089B	80000	A070URD30XXX0200	A070URD30XXX0200	A070URD30XXX0200
MCD5-0105B	125000	A070URD30XXX0315	A070URD30XXX0315	A070URD30XXX0315
MCD5-0131B	125000	A070URD30XXX0315	A070URD30XXX0315	A070URD30XXX0315
MCD5-0141B	320000	A070URD30XXX0315	A070URD30XXX0315	A070URD30XXX0315
MCD5-0195B	320000	A070URD30XXX0450	A070URD30XXX0450	A070URD30XXX0450
MCD5-0215B	320000	A070URD30XXX0450	A070URD30XXX0450	A070URD30XXX0450
MCD5-0245B	32000	A070URD30XXX0450	A070URD30XXX0450	A070URD30XXX0450
MCD5-0331B	202000	A070URD31XXX0550	-	-
MCD5-0396B	238000	A070URD32XXX0630	-	-
MCD5-0469B	320000	A070URD32XXX0700	-	-
MCD5-0525B	781000	A070URD32XXX0800	-	-
MCD5-0632B	781000	A070URD33XXX0900	-	-
MCD5-0744B	1200000	A070URD33XXX1100	-	-
MCD5-0826B	2530000	A070URD33XXX1250	-	-
MCD5-0961B	2530000	A070URD33XXX1400	-	-
MCD5-0245C	320000	A070URD30XXX0450	A070URD30XXX0450	A070URD30XXX0450
MCD5-0360C	320000	A070URD33XXX0630	A070URD33XXX0630	A070URD33XXX0630
MCD5-0380C	320000	A070URD33XXX0700	A070URD33XXX0700	-
MCD5-0428C	320000	A070URD33XXX0700	A070URD33XXX0700	-
MCD5-0595C	1200000	A070URD33XXX1000	A070URD33XXX1000	A070URD33XXX1000
MCD5-0619C	1200000	A070URD33XXX1000	A070URD33XXX1000	A070URD33XXX1000
MCD5-0790C	2530000	A070URD33XXX1400	A070URD33XXX1400	A070URD33XXX1400
MCD5-0927C	4500000	A070URD33XXX1400	A070URD33XXX1400	A070URD33XXX1400
MCD5-1200C	4500000	A055URD33XXX2250	-	-
MCD5-1410C	6480000	A055URD33XXX2250	-	-
MCD5-1600C	12500000	-	-	-

Table 4.10 North American Style (PSC 690)

Model	SCR I ² t (A ² s)	Supply voltage	Supply voltage	Supply voltage
		(<440 V AC)	(<575 V AC)	(<690 V AC)
MCD5-0021B	1150	6.9URD30D11A0050	6.9URD30D11A0050	6.9URD30D11A0050
MCD5-0037B	8000	6.9URD30D11A0125	6.9URD30D11A0125	6.9URD30D11A0125
MCD5-0043B	10500	6.9URD30D11A0125	6.9URD30D11A0125	6.9URD30D11A0125
MCD5-0053B	15000	6.9URD30D11A0125	6.9URD30D11A0125	6.9URD30D11A0125
MCD5-0068B	15000	6.9URD30D11A0160	6.9URD30D11A0160	6.9URD30D11A0160
MCD5-0084B	51200	6.9URD30D11A0200	6.9URD30D11A0200	6.9URD30D11A0200
MCD5-0089B	80000	6.9URD30D11A0200	6.9URD30D11A0200	6.9URD30D11A0200
MCD5-0105B	125000	6.9URD30D11A0315	6.9URD30D11A0315	6.9URD30D11A0315
MCD5-0131B	125000	6.9URD30D11A0315	6.9URD30D11A0315	6.9URD30D11A0315
MCD5-0141B	320000	6.9URD30D11A0315	6.9URD30D11A0315	6.9URD30D11A0315
MCD5-0195B	320000	6.9URD31D11A0450	6.9URD31D11A0450	6.9URD31D11A0450
MCD5-0215B	320000	6.9URD31D11A0450	6.9URD31D11A0450	6.9URD31D11A0450
MCD5-0245B	320000	6.9URD31D11A0450	6.9URD31D11A0450	6.9URD31D11A0450

Model	SCR I ² t (A ² s)	Supply voltage	Supply voltage	Supply voltage
		(<440 V AC)	(<575 V AC)	(<690 V AC)
MCD5-0331B	202000	6.9URD31D11A0550	-	-
MCD5-0396B	320000	6.9URD32D11A0630	-	-
MCD5-0469B	320000	6.9URD32D11A0700	-	-
MCD5-0525B	781000	6.9URD32D11A0800	-	-
MCD5-0632B	781000	6.9URD33D11A0900	-	-
MCD5-0744B	1200000	6.9URD33D11A1100	-	-
MCD5-0826B	2530000	6.9URD33D11A1250	-	-
MCD5-0961B	2530000	6.9URD33D11A1400	-	-
MCD5-0245C	320000	6.9URD31D11A0450	6.9URD31D11A0450	6.9URD31D11A0450
MCD5-0360C	320000	6.9URD33D11A0630	6.9URD33D11A0630	6.9URD33D11A0630
MCD5-0380C	320000	6.9URD33D11A0700	6.9URD33D11A0700	6.9URD33D11A0700
MCD5-0428C	320000	6.9URD33D11A0700	6.9URD33D11A0700	6.9URD33D11A0700
MCD5-0595C	1200000	6.9URD33D11A1000	6.9URD33D11A1000	6.9URD33D11A1000
MCD5-0619C	1200000	6.9URD33D11A1000	6.9URD33D11A1000	6.9URD33D11A1000
MCD5-0790C	2530000	6.6URD33D11A1400	6.6URD33D11A1400	-
MCD5-0927C	4500000	6.6URD33D11A1400	6.6URD33D11A1400	-
MCD5-1200C	4500000	6URD233PLAF2200	6URD233PLAF2200	-
MCD5-1410C	6480000	6URD233PLAF2200	6URD233PLAF2200	-
MCD5-1600C	12500000	6URD233PLAF2800	6URD233PLAF2800	-

Table 4.11 European Style (PSC 690)

4.10.4 UL Fuse Selection and Short Circuit Ratings

2 short circuit current ratings (SCCR) are available for UL-compliant applications.

Standard fault currents (@600 V AC circuits)

The standard fault currents are determined referring to UL 508, section 1, table 51.2. This standard specifies the short circuit current that the soft starter must withstand based on the horse power rating (or full load current (FLC) rating, or locked rotor amps (LRA) depending on the model).

If using the standard fault current ratings, the fuse must be in accordance with the information in *Table 4.12* (that is model- and manufacturer-specific).

High available fault currents (@480 V AC circuits)

It is possible to specify short circuit current ratings exceeding the minimum ratings set by the standard fault currents when the soft starter is capable of withstanding the high available short circuit current in accordance with the UL 508 test.

If using the high available fault current ratings, select a suitable fuse based on amperage and fuse class (J or L as applicable).

Model	Nominal rating [A]	Short circuit ratings					600 V short circuit current rating [kA] 3 cycles ¹⁾	
		High available		Standard fault current				
		@ 480 V AC maximum [kA]	Maximum fuse rating [A] (fuse class)	@ 600 V AC [kA]	Ferraz/Mersen fuse, listed J, L, or RK5 class fuse	Ferraz/Mersen fuse, R/C semiconductor fuses		
Bypassed models								
MCD5-0021B	23	65	25 (J)	10	AJT25	A070URD30XXX0063	N/A	
MCD5-0037B	43	65	50 (J)	10	AJT50	A070URD30XXX0125		
MCD5-0043B	50	65	50 (J)	10	AJT50	A070URD30XXX0125		
MCD5-0053B	53	65	60 (J)	10	AJT60	A070URD30XXX0125		
MCD5-0068B	76	65	80 (J)	10	AJT80	A070URD30XXX0200		
MCD5-0084B	97	65	100 (J)	10	AJT100	A070URD30XXX0200		
MCD5-0089B	100	65	100 (J)	10	AJT100	A070URD30XXX0200		
MCD5-0105B	105	65	125 (J)	10	AJT125	A070URD30XXX0315		
MCD5-0131B	145	65	150 (J)	18	AJT150/RK 5 200	A070URD30XXX0315		
MCD5-0141B	170	65	175 (J)	18	AJT175/RK 5 200	A070URD30XXX0315		
MCD5-0195B	200	65	200 (J)	18	AJT200/RK 5 300	A070URD30XXX0450		
MCD5-0215B	220	65	250 (J)	18	AJT250/RK 5 300	A070URD30XXX0450		
MCD5-0245B	255	65	350 (RK1/J)	18	1)	-		18
MCD5-0331B	350	65	400 (J)	18	1)	-		3 cycles
MCD5-0396B	425	65	450 (J)	30	1)	A070URD33XXX0630		30
MCD5-0469B	500	65	600 (J)	30	600, class J	A070URD33XXX0700	3 cycles	
MCD5-0525B	580	65	800 (L)	30	800, Class L	-	42 3 cycles	
MCD5-0632B	700	65	800 (L)	42	800, Class L	-		
MCD5-0744B	820	65	1200 (L)	42	1200, Class L	A070URD33XXX1000		
MCD5-0826B	920	65	1200 (L)	85	1200, Class L	A070URD33XXX1400		
MCD5-0961B	1000	65	1200 (L)	85	1200, Class L	A070URD33XXX1400		
Non-bypassed models								
MCD5-0245C	255	65	350 (RK1/J)	18	AJT300	A070URD30XXX0450	N/A	
MCD5-0360C	360	65	400 (J)	18	AJT400/RK 5 500	A070URD33XXX0630		
MCD5-0380C	380	65	450 (J)	18	AJT450/RK 5 500	A070URD33XXX0700		
MCD5-0428C	430	65	450 (J)	30	AJT450	A070URD33XXX0700		
MCD5-0595C	620	65	800 (L)	42	A4BQ800	A070URD33XXX1000		
MCD5-0619C	650	65	800 (L)	42	A4BQ800	A070URD33XXX1000		
MCD5-0790C	790	65	1200 (L)	42	A4BQ1200	070URD33XXX1400		
MCD5-0927C	930	65	1200 (L)	42	A4BQ1200	A070URD33XXX1400		
MCD5-1200C	1200	65	1600 (L)	85	A4BQ1600	A065URD33XXX1800		
MCD5-1410C	1410	65	2000 (L)	85	A4BQ2000	A055URD33XXX2250		
MCD5-1600C	1600	65	2000 (L)	85	A4BQ2500	A055URD33XXX2500		

Table 4.12 Short Circuit Ratings

XXX = blade type: See Ferraz/Mersen catalog for details.

1) When protected by any UL-listed fuses or UL-listed circuit breakers sized according to the NEC, models provided with a 3-cycle rating are suitable for use in a circuit with the prospective current noted.

4.11 Schematic Diagrams

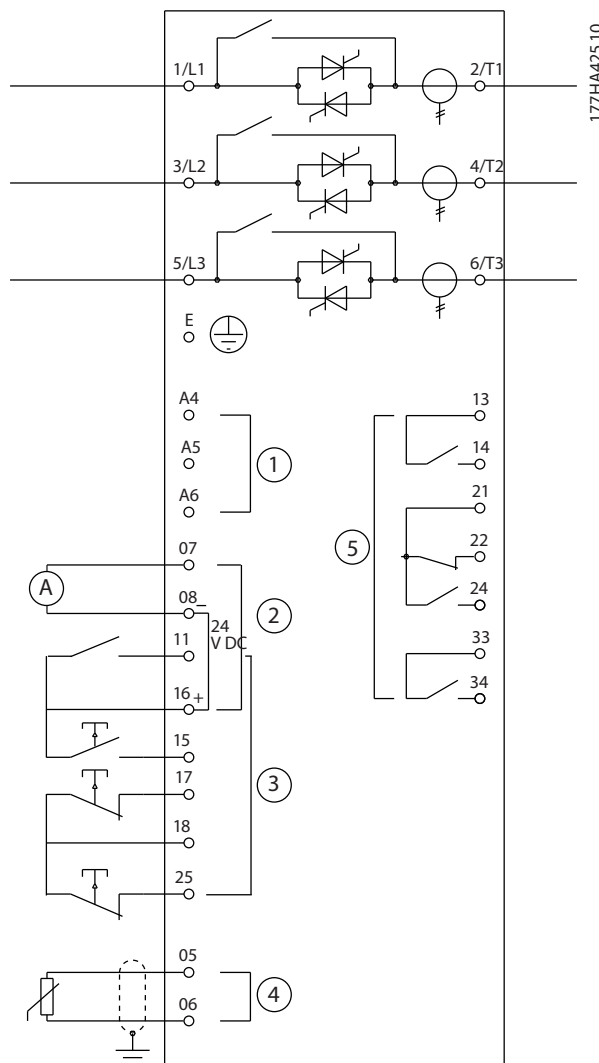

177HA425.10

4

1	Control supply (model dependent)	11, 16	Programmable input
2	Outputs	15, 16	Start
3	Remote control inputs	17, 18	Stop
4	Motor thermistor input (PTC only)	25, 18	Reset
5	Relay outputs	13, 14	Relay output A
07, 08	Programmable analog output	21, 22, 24	Relay output B
16, 08	24 V DC output	33, 34	Relay output C

Illustration 4.18 Internally Bypassed Models

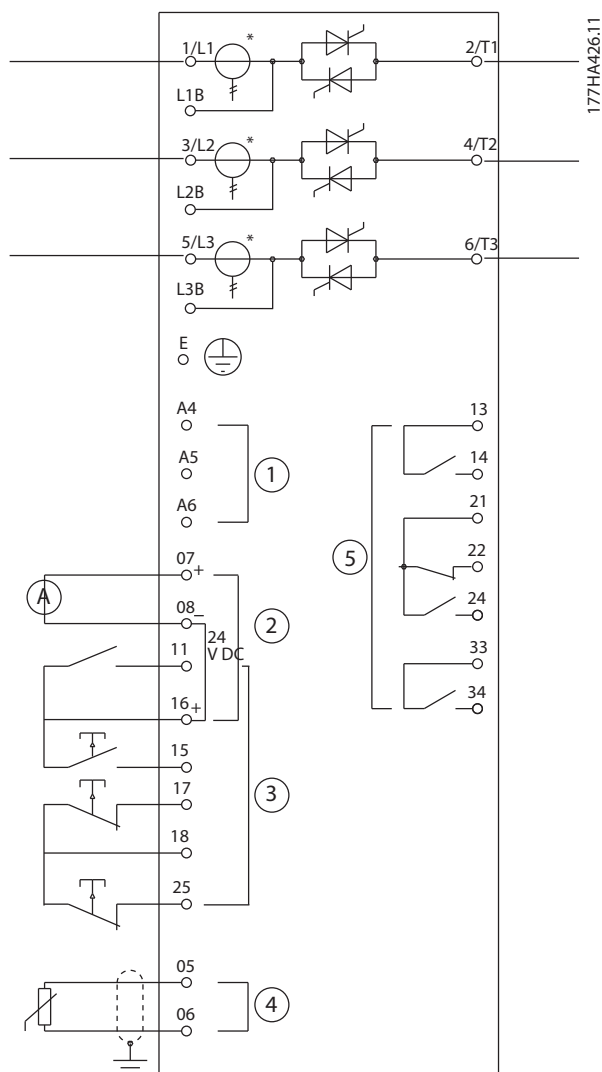

1	Control supply (model dependent)	11, 16	Programmable input
2	Outputs	15, 16	Start
3	Remote control inputs	17, 18	Stop
4	Motor thermistor input (PTC only)	25, 18	Reset
5	Relay outputs	13, 14	Relay output A
07, 08	Programmable analog output	21, 22, 24	Relay output B
16, 08	24 V DC output	33, 34	Relay output C

Illustration 4.19 Non-bypassed Models

* MCD5-0245C current transformers are located on the output. Bypass terminals are labelled T1B, T2B and T3B.

5 Product Features

5.1 Motor Overload Protection

The thermal model used for motor overload in the soft starter has 2 components:

- Motor windings: The motor windings have a low thermal capacity and affect the short-term thermal behaviour of the motor. The motor windings are where the current generates heat.
- Motor body: The motor body has a large thermal capacity and affects the long-term behaviour of the motor. The thermal model includes considerations for the following:
 - Motor current.
 - Iron losses.
 - Winding resistance losses.
 - Motor body and winding thermal capacities.
 - Cooling during run and cooling at standstill.
 - The percentage of the rated capacity of the motor. This sets the displayed value for the winding model and is affected by the motor FLC setting among others.

NOTICE

Set parameter 1-1 Motor FLC to the rated motor FLC. Do not add the overload rating as the soft starter calculates this rating.

The thermal overload protection used in the soft starter has a number of advantages over the thermal relays.

- The effect of fan cooling is accounted for when the motor is running.
- The actual full load current and locked rotor time can be used to more accurately tune the model. The thermal characteristics of the windings are treated separately from the rest of the motor (that is the model recognises that the windings have low thermal mass and high thermal resistance).
- The winding portion of the thermal model responds rapidly compared with the body portion. Thus, the motor can be run closer to its safe maximum operating temperature while still being protected from thermal damage.
- The percentage of motor thermal capacity used during each start is stored in memory. The soft starter can be configured to determine automat-

ically whether the motor has sufficient thermal capacity remaining to complete another start successfully.

- The memory function of the model means that the motor is fully protected in warm-start situations. The model uses data from the real-time clock to account for elapsed cooling time, even if control power has been removed.

The overload protection function provided by this model is compliant with a NEMA 10 curve, but provides superior protection at low levels of overload due to the separation of the winding thermal model.

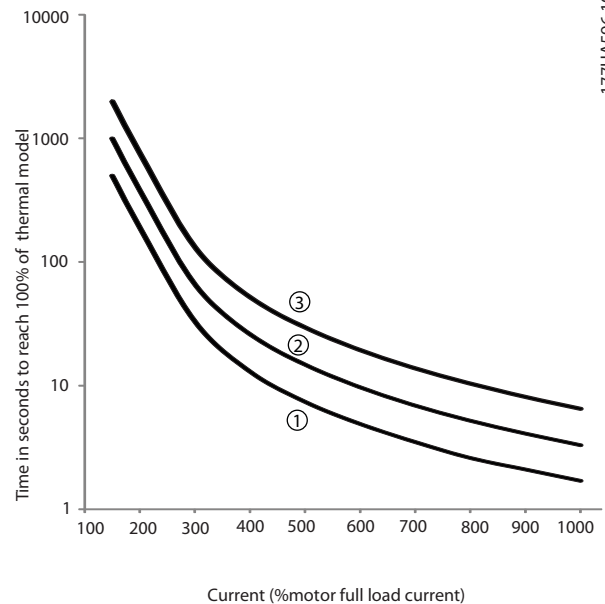

Illustration 5.1 Protection Degree Compared to Overload

1. MSTC¹⁾=5
2. MSTC¹⁾=10
3. MSTC¹⁾=20

1) MSTC is the motor start time constant. It is defined as the locked rotor time (in parameter 1-2 Locked Rotor Time) when the locked rotor current is 600% of FLC.

5.2 Adaptive Control

Adaptive control is motor control based on the performance characteristics of the motor. With adaptive control, select the starting or stopping profile that best matches the load type. The soft starter automatically controls the motor to match the profile. The MCD 500 offers 3 profiles:

- Early acceleration and deceleration.
- Constant acceleration and deceleration.
- Late acceleration and deceleration.

Adaptive control uses 2 algorithms, 1 to measure the motor characteristics, and 1 to control the motor. The soft starter uses the first start to determine the motor characteristics at zero speed and at maximum speed. During each subsequent start and stop, the soft starter dynamically adjusts its control to ensure that the actual motor performance matches the selected profile throughout the start. If the actual speed is too low for the profile, the soft starter increases power to the motor. If the speed is too high, the soft starter decreases power.

5.3 Starting Modes

5.3.1 Constant Current

Constant current is the traditional form of soft starting. It raises the current from zero to a specified level and keeps the current stable at that level until the motor has accelerated.

Constant current starting is ideal for applications where the start current must be kept below a particular level.

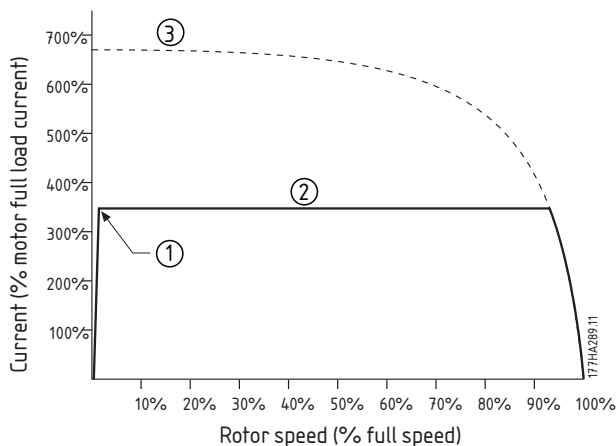

1	Parameter 1-5 Initial current
2	Parameter 1-4 Current limit
3	Full voltage current

Illustration 5.2 Example of Constant Current

5.3.2 Current Ramp

Current ramp soft starting raises the current from a specified starting level (1) to a maximum limit (3), over an extended period (2).

Current ramp starting can be useful for applications where:

- The load can vary between starts (for example a conveyor which may start loaded or unloaded). Set *parameter 1-5 Initial Current* to a level that starts the motor with a light load. Set *parameter 1-4 Current Limit* to a level that starts the motor with a heavy load.
- The load breaks away easily, but starting time must be extended (for example a centrifugal pump where pipeline pressure must build up slowly).
- The electricity supply is limited (for example a generator set), and a slower application of load allows greater time for the supply to respond.

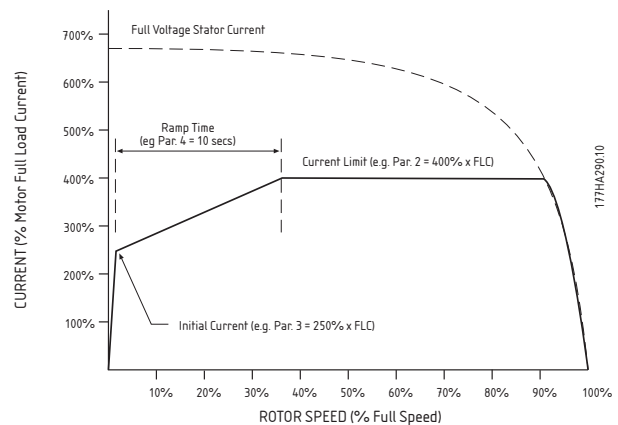

1	Parameter 1-5 Initial current
2	Parameter 1-6 Start ramp time
3	Parameter 1-4 Current limit
4	Full voltage current

Illustration 5.3 Example of a 10 s Current Ramp Time

5.3.3 Adaptive Control

In an adaptive control soft start, the soft starter adjusts the current to start the motor within a specified time and using a selected acceleration profile.

CAUTION

Adaptive control cannot start the motor faster than a direct on-line (DOL) start. If the time set in *parameter 1-6 Start ramp time* is shorter than the motor DOL start time, starting current may reach DOL levels.

Every application has a particular starting profile based on characteristics of the load and the motor. To suit the requirements of different applications, adaptive control offers 3 different starting profiles. Selecting a profile that

matches the inherent profile of the application can help smooth out acceleration across the full start time. Selecting a very different adaptive control-profile can neutralise the inherent profile to some extent.

To use adaptive control to control starting performance:

1. Select *Adaptive control* in *parameter 1-3 Start Mode*.
2. Set *parameter 1-6 Start Ramp Time*.
3. Select the desired profile in *parameter 1-13 Adaptive Start Profile*.
4. Set *parameter 1-4 Current Limit* sufficiently high to allow a successful start.

The first adaptive control start is a constant current start. This start type allows the soft starter to learn the characteristics of the connected motor. The soft starter uses this motor data during subsequent adaptive control starts.

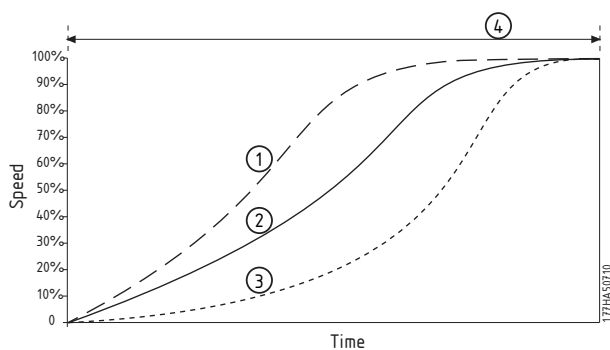

1	Early acceleration
2	Constant acceleration
3	Late acceleration
4	Parameter 1-16 Start Ramp Time

Illustration 5.4 Parameter 1-13 Adaptive Start Profile

NOTICE

Adaptive control controls the load according to the programmed profile. Start current varies according to the selected acceleration profile and the programmed start time.

The soft starter has to learn the characteristics of a new motor:

- If replacing a motor connected to a soft starter programmed for adaptive control starting or stopping.
- If the soft starter has been tested on a different motor before actual installation.

If *parameter 1-1 Motor Full Load Current* or *parameter 1-12 Adaptive Control Gain* is changed, the soft starter automatically re-learns the motor characteristics.

5.3.4 Kick Start

Kick start provides a short boost of extra torque at the beginning of a start, and can be used with current ramp or constant current starting.

Kick start can be useful to help start loads that require high breakaway torque but then accelerate easily (for example flywheel loads such as presses).

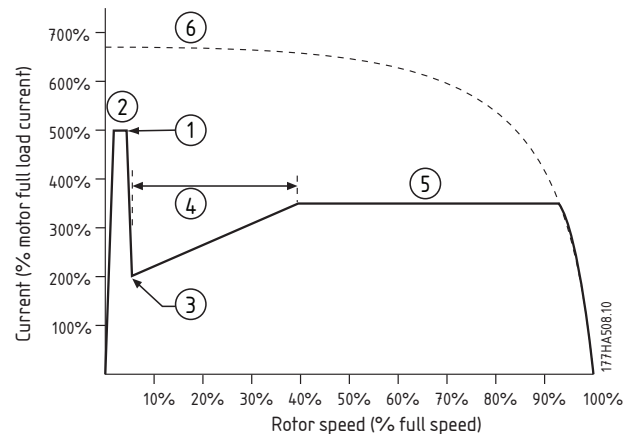

1	Parameter 1-7 Kick Start Level
2	Parameter 1-8 Kick Start Time
3	Parameter 1-5 Initial Current
4	Parameter 1-6 Start Ramp Time
5	Parameter 1-4 Current Limit
6	Full voltage current

Illustration 5.5 Example of Rotor Speed when using Kick Start

5.4 Stopping Modes

5.4.1 Coast to Stop

Coast to stop lets the motor slow at its natural rate, with no control from the soft starter. The time required to stop depends on the type of load.

5.4.2 TVR Soft Stop

Timed voltage ramp reduces the voltage to the motor gradually over a defined time. The load may continue to run after the stop ramp is complete.

Timed voltage ramp stopping can be useful for applications where the stop time has to be extended, or to avoid transients on generator-set supplies.

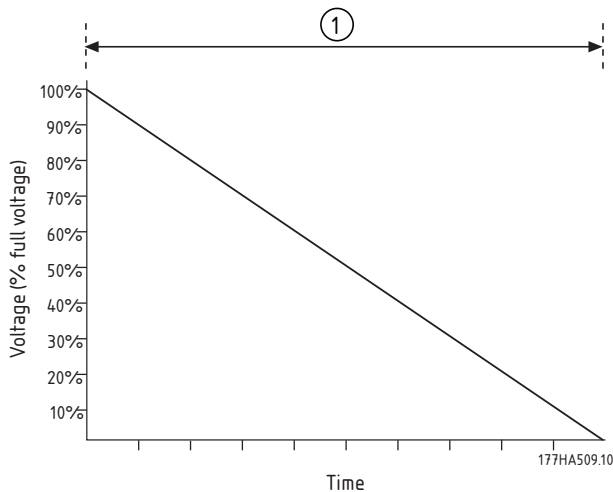

1 Parameter 1-11 Stop Time

Illustration 5.6 TVR Soft Stop

5.4.3 Adaptive Control

To use adaptive control to control stopping performance:

1. Select *Adaptive control* from the *Stop Mode* menu.
2. Set *parameter 1-11 Stop Time*.
3. Select the required profile in *parameter 1-14 Adaptive Stop Profile*.

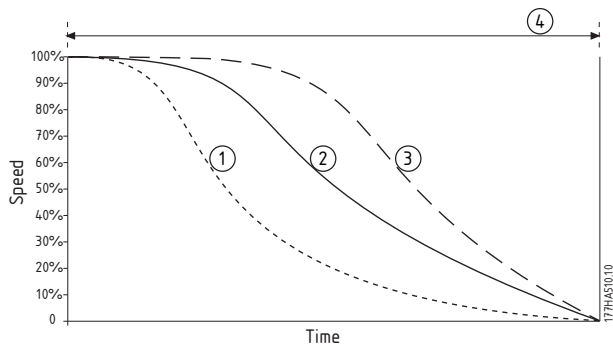

1	Early deceleration
2	Constant deceleration
3	Late deceleration
4	Parameter 1-10 Stop Time

Illustration 5.7 Parameter 1-14 Adaptive Stop Profile

NOTICE

Adaptive control does not actively slow the motor down and does not stop the motor faster than a coast to stop. To shorten the stopping time of high-inertia loads, use a brake function, see *chapter 5.4.5 Brake*.

The first adaptive control stop is a normal soft stop. This stop type allows the soft starter to learn the characteristics of the connected motor. The soft starter uses this motor data during subsequent adaptive control stops.

NOTICE

Adaptive control controls the load according to the programmed profile. Stopping current varies according to the selected deceleration profile and stop time. The soft starter has to learn the characteristics of a new motor:

- If replacing a motor connected to soft starter programmed for adaptive control starting or stopping.
- if the soft starter has been tested on a different motor before actual installation.

If *parameter 1-1 Motor Full Load Current* or *parameter 1-12 Adaptive Control Gain* is changed, the soft starter automatically re-learns the motor characteristics.

5.4.4 Pump Stopping

The hydraulic characteristics of pump systems vary considerably. This variation means the ideal deceleration profile and stop time vary from application to application. *Table 5.1* provides guidelines on selecting between adaptive control-profiles. For identification of the best profile for the application, test all 3 profiles.

Adaptive stop profile	Application
Late deceleration	High-head systems, where even a small decrease in motor/pump speed results in a rapid transition between forward flow and reverse flow.
Constant deceleration	Low to medium head, high-flow applications where the fluid has high momentum.
Early deceleration	Open pump systems, where fluid must drain back through the pump without driving the pump in reverse.

Table 5.1 Selection of Adaptive Control Deceleration Profiles

5.4.5 Brake

Brake reduces the time the motor requires to stop.

During braking, an increased noise level from the motor may be audible. This noise is a normal part of motor braking.

CAUTION

EQUIPMENT DAMAGE

If the brake torque is set too high, the motor stops before the end of the brake time. The motor suffers unnecessary heating which could result in damage. Careful configuration is required to ensure safe operation of the soft starter and the motor.

A high brake torque setting can result in peak currents up to motor DOL being drawn while the motor is stopping. Ensure that protection fuses installed in the motor branch circuit are selected appropriately.

CAUTION

RISK OF OVERHEATING

Brake operation causes the motor to heat faster than the rate calculated by the motor thermal model. If using brake functionality, install a motor thermistor or allow sufficient restart delay (*parameter 2-11 Restart Delay*).

When brake is selected, the soft starter uses DC injection to slow the motor.

MCD 500 braking

- Does not require the use of a DC brake contactor.
- Controls all 3 phases so that the braking currents and associated heating are evenly distributed through the motor.

Braking has 2 stages:

1. Pre-brake: Provides an intermediate level of braking to slow motor speed to a point where full brake can be operated successfully (approximately 70% speed).
2. Full brake: Provides maximum braking torque but is ineffective at speeds greater than approximately 70%.

To configure the MCD 500 for brake operation:

1. Set *parameter 1-11 Stop Time* for the desired stopping time duration (1). The stop time is the total braking time and must be set sufficiently longer than the brake time (*parameter 1-16 Brake Time*) to allow the pre-braking stage to reduce motor speed to approximately 70%. If the stop time is too short, braking is not successful and the motor coasts to stop.
2. Set *parameter 1-16 Brake Time* to approximately one quarter of the programmed stop time. The brake time sets the time for the full brake-stage (2).

3. Adjust *parameter 1-15 Brake Torque* so that the desired stopping performance is achieved. If set too low, the motor does not stop completely and coasts to stop by the end of the braking period.

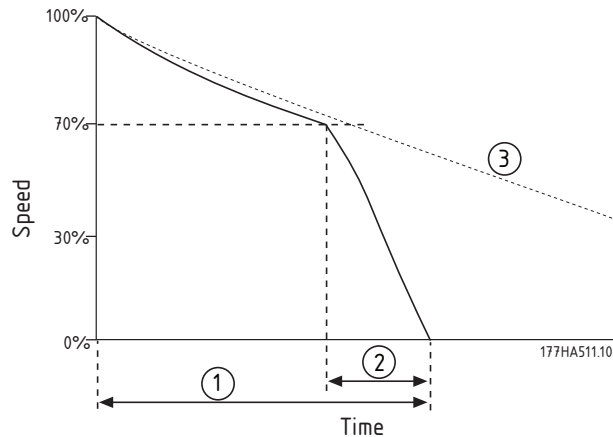

1	Parameter 1-11 Stop Time
2	Parameter 1-16 Brake Time
3	Coast to stop time

Illustration 5.8 Brake Time

CAUTION

When using DC brake:

1. Connect the mains supply to the soft starter (input terminals L1, L2, L3) in positive phase sequence.
2. Set *parameter 2-1 Phase Sequence to Positive only*.

NOTICE

For loads which may vary between braking cycles, install a zero-speed sensor to ensure that the soft starter ends DC braking when the motor stops. This installation avoids unnecessary heating of the motor.

For more information on using the MCD 500 with an external speed sensor (for example for applications with variable load during the braking cycle), see *chapter 5.12 DC Brake with External Zero-speed Sensor*.

5.5 Jog Operation

Jog runs the motor at reduced speed, to allow alignment of the load or to assist servicing. The motor can be jogged in either forward or reverse direction.

The maximum available torque for jog forward is approximately 50–75% of motor full load torque (FLT) depending on the motor. The torque when the motor is jogged in reverse is approximately 25–50% of FLT. *Parameter 15-8 Jog*

Torque controls how much of the maximum available jog torque the soft starter applies to the motor.

NOTICE

Setting parameter 15-8 Jog Torque above 50% may cause increased shaft vibration.

5

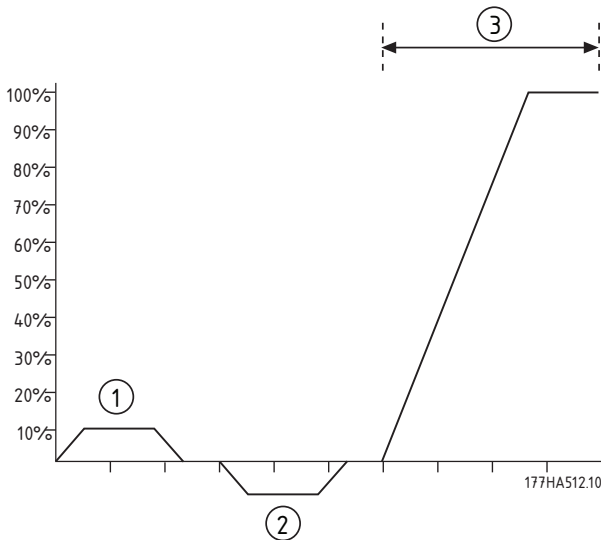

1	Jog forward
2	Jog reverse
3	Normal operation

Illustration 5.9 Jog Operation

To activate jog operation, use a programmable input (parameter 3-3 Input A Function).

To stop a jog operation, perform either of the following:

- Remove the jog command.
- Press [Off] on the LCP.
- Activate *Starter disable* using the LCP programmable inputs.

If the jog command is still present, jog recommences at the end of a restart delay. All other commands except the ones listed are ignored during jog operation.

NOTICE

Soft start and soft stop are not available during jog operation. Jog is only available for the primary motor.

CAUTION

Slow speed running is not intended for continuous operation due to reduced motor cooling. Jog operation causes the motor to heat faster than the rate calculated by the motor thermal model. If using jog, install a motor thermistor, or allow sufficient restart delay (parameter 2-11 Restart Delay).

5.6 Inside Delta Operation

Adaptive control, jog, and brake functions are not supported in inside delta (6-wire) operation. If these functions are programmed when the soft starter is connected inside delta, the behaviour is as in Table 5.2:

Adaptive control start	The soft starter performs a constant current start.
Adaptive control stop	If stop time is >0 s, the starter performs a TVR soft stop. If stop time is set to 9 s, the starter performs a coast to stop.
Jog	The soft starter issues a warning with the error message <i>Unsupported Option</i> .
Brake	The starter performs a coast to stop.

Table 5.2 Inside Delta Behaviour at Adaptive Control, Jog, and Brake

NOTICE

When connected in inside delta, current imbalance is the only phase loss protection that is active during run. Do not disable parameter 2-2 Current Imbalance during inside delta operation.

NOTICE

Inside delta operation is only possible with mains voltage ≤600 V AC.

5.7 Typical Start Currents

To determine the typical start current for an application, use this information.

NOTICE

These start current requirements are appropriate and typical in most circumstances, However, the performance and start torque requirements of motors and machines do vary. For further assistance, contact the local Danfoss supplier.

General and water

Agitator	4.0 FLC
Centrifugal pump	3.5 x FLC
Compressor (Screw, unloaded)	3.0 x FLC
Compressor (Reciprocating, unloaded)	4.0 x FLC
Conveyor	4.0 x FLC
Fan (damped)	3.5 x FLC
Fan (undamped)	4.5 x FLC
Mixer	4.5 x FLC
Positive displacement pump	4.0 x FLC
Submersible pump	3.0 x FLC

Table 5.3 Typical Start Currents for General and Water Applications

Metals and mining

Belt conveyor	4.5 x FLC
Dust collector	3.5 x FLC
Grinder	3.0 x FLC
Hammer mill	4.5 x FLC
Rock crusher	4.0 x FLC
Roller conveyor	3.5 x FLC
Roller mill	4.5 x FLC
Tumbler	4.0 x FLC
Wire draw-machine	5.0 x FLC

Table 5.4 Typical Start Currents for Metals and Mining Applications

Food processing

Bottle washer	3.0 x FLC
Centrifuge	4.0 x FLC
Dryer	4.5 x FLC
Mill	4.5 x FLC
Palletiser	4.5 x FLC
Separator	4.5 x FLC
Slicer	3.0 x FLC

Table 5.5 Typical Start Currents for Food Processing Applications

Pulp and paper

Dryer	4.5 x FLC
Re-pulper	4.5 x FLC
Shredder	4.5 x FLC

Table 5.6 Typical Start Currents for Pulp and Paper Applications

Petrochemical

Ball mill	4.5 x FLC
Centrifuge	4.0 x FLC
Extruder	5.0 x FLC
Screw conveyor	4.0 x FLC

Table 5.7 Typical Start Currents for Petrochemical Applications

Transport and machine tool

Ball mill	4.5 x FLC
Grinder	3.5 x FLC
Material conveyor	4.0 x FLC
Palletiser	4.5 x FLC
Press	3.5 x FLC
Roller mill	4.5 x FLC
Rotary table	4.0 x FLC

Table 5.8 Typical Start Currents for Transport and Machine Tool Applications

Lumber and wood products

Bandsaw	4.5 x FLC
Chipper	4.5 x FLC
Circular saw	3.5 x FLC
Debarker	3.5 x FLC
Edger	3.5 x FLC
Hydraulic power pack	3.5 x FLC
Planer	3.5 x FLC
Sander	4.0 x FLC

Table 5.9 Typical Start Currents for Lumber and Wood Products Applications

5.8 Installation with Main Contactor

The MCD 500 is installed with a main contactor (AC3 rated). Supply control voltage from the input side of the contactor. The soft starter main contactor output controls the main contactor. The main contactor output is by default assigned to output relay A (terminals 13, 14).

5

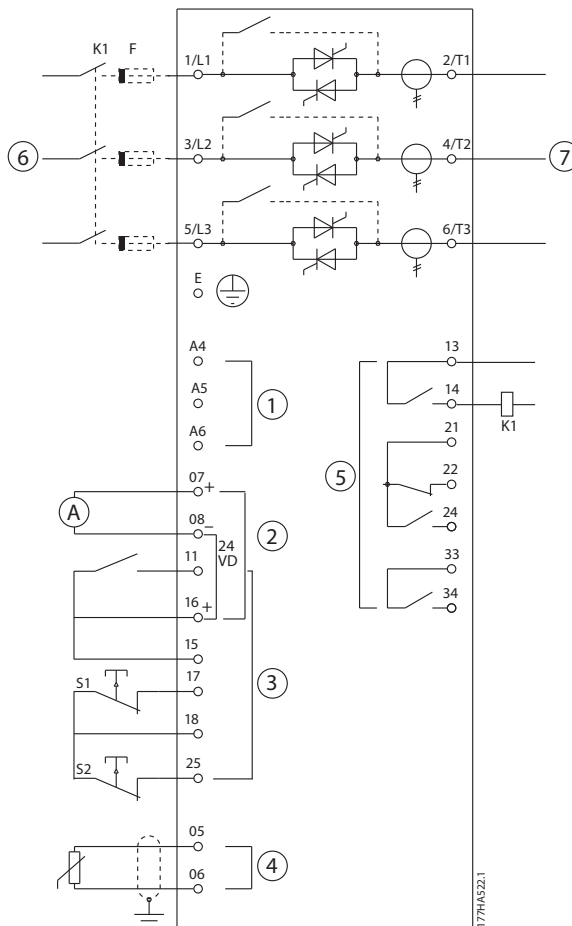

1	Control voltage (model dependent)	K1	Main contactor
2	24 V DC output	F1	Semiconductor fuses (optional)
3	Remote control inputs	S1	Start/stop
4	Motor thermistor input (PTC only)	S2	Reset contact
5	Relay outputs	13, 14	Relay output A
6	3-phase supply	21, 22, 24	Relay output B
7	Motor terminals	33, 34	Relay output C

Illustration 5.10 Installation with Main Contactor

Parameter settings:

- *Parameter 4-1 Relay A Function*
 - Select *Main contactor* - assigns the main contactor-function to relay output A (default value).

5.9 Installation with Bypass Contactor

The MCD 500 is installed with a bypass contactor (AC1 rated). The soft starter run-output controls the bypass contactor. The run output is by default assigned to output relay B (terminals 21, 22, 24).

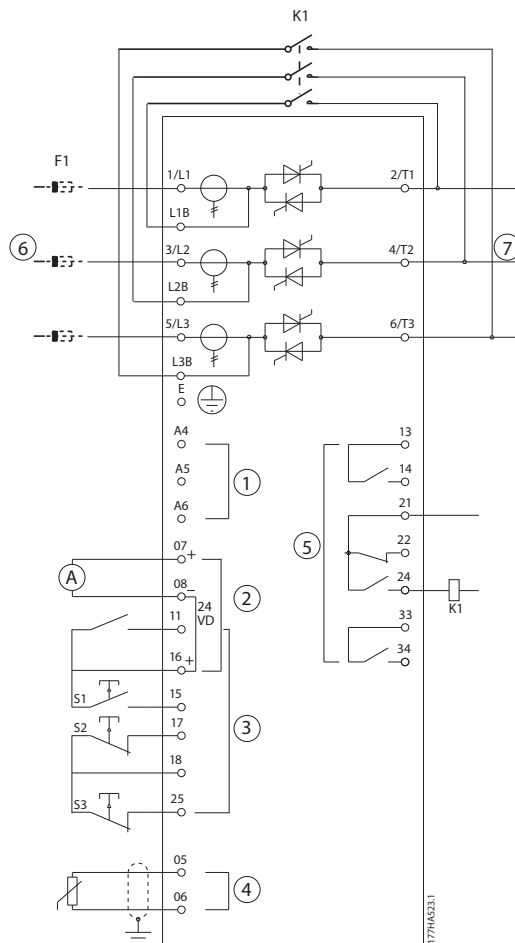

5

1	Control voltage (model dependent)	K1	Bypass contactor
2	24 V DC output	F1	Semiconductor fuses (optional)
3	Remote control inputs	S1	Start contact
4	Motor thermistor input (PTC only)	S2	Stop contact
5	Relay outputs	S3	Reset contact
6	3-phase supply	13, 14	Relay output A
7	Motor terminals	21, 22, 24	Relay output B
		33, 34	Relay output C

Illustration 5.11 Installation with Bypass Contactor

Parameter settings:

- *Parameter 4-4 Relay B Function*
 - Select *Run* - assigns the run output function to output relay B (default value).

5.10 Emergency Run Operation

In normal operation, the MCD 500 is controlled via a remote 2-wire signal (terminals 17, 18).

A 2-wire circuit connected to input A (terminals 11, 16) controls emergency run. Closing input A causes the soft starter to run the motor and ignore all trip conditions.

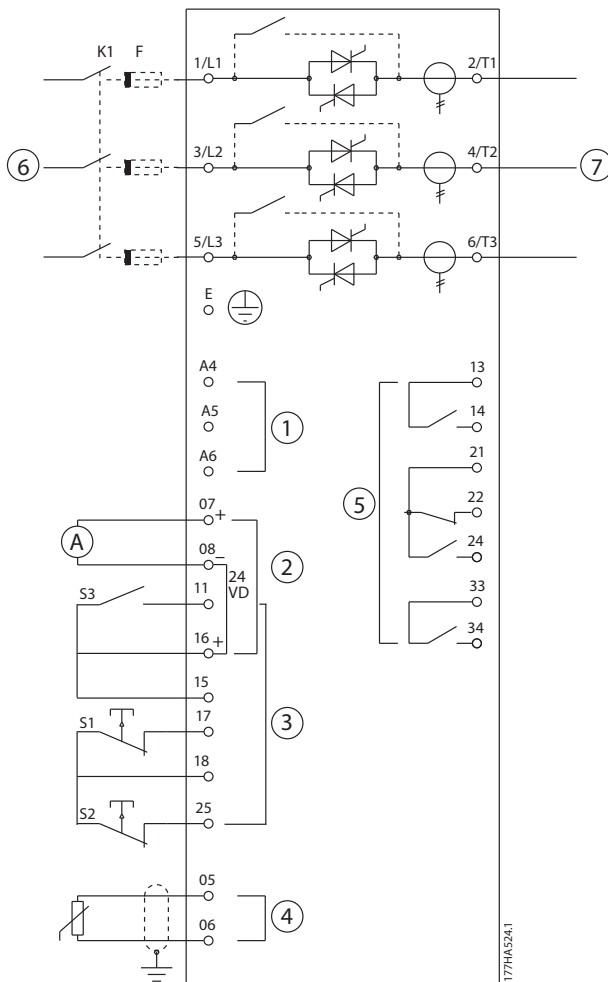

1	Control voltage (model dependent)	S1	Start/stop contact
2	24 V DC output	S2	Reset contact
3	Remote control inputs	S3	Emergency run-contact
4	Motor thermistor input (PTC only)	13, 14	Relay output A
5	Relay outputs	21, 22, 24	Relay output B
6	3-phase supply	33, 34	Relay output C
7	Motor terminals		

Illustration 5.12 Emergency Run Operation

Parameter settings:

- *Parameter 3-3 Input A Function.*
 - Select *Emergency Run* - assigns input A to emergency run-function.
- *Parameter 15-3 Emergency Run.*
 - Select *Enable* - Enables the emergency run-mode.

NOTICE

Although *Emergency run* satisfies the functionality requirements of *Fire mode*, Danfoss does not recommend its use in situations that require testing and/or compliance with specific standards as it is not certified.

5.11 Auxiliary Trip Circuit

In normal operation, the MCD 500 is controlled via a remote 2-wire signal (terminals 17, 18).

Input A (terminals 11, 16) is connected to an external trip circuit (such as a low-pressure alarm switch for a pumping system). When the external circuit activates, the soft starter trips and stops the motor.

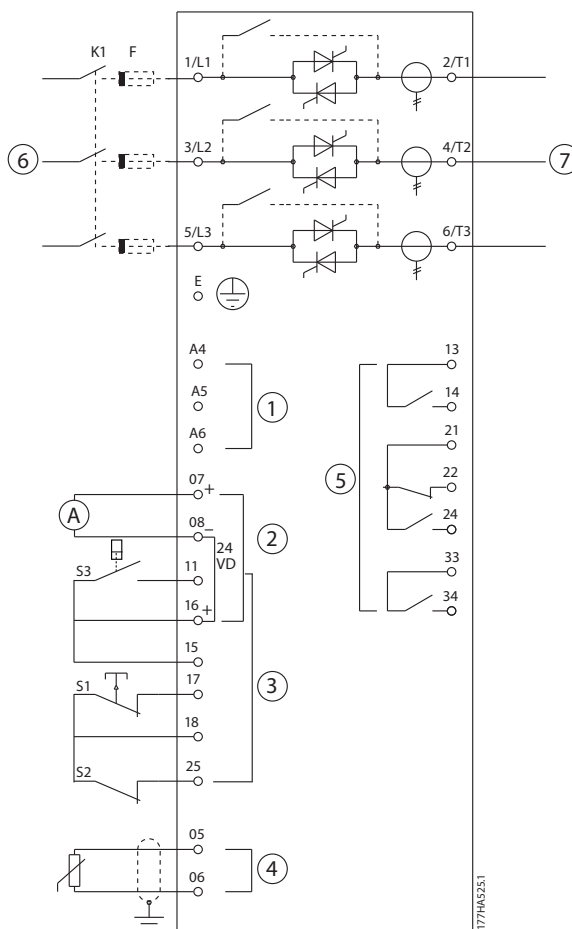

5

1	Control voltage (model dependent)	S1	Start/stop contact
2	24 V DC output	S2	Reset contact
3	Remote control inputs	S3	Auxiliary trip contact
4	Motor thermistor input (PTC only)	13, 14	Relay output A
5	Relay outputs	21, 22, 24	Relay output B
6	3-phase supply	33, 34	Relay output C
7	Motor terminals		

Illustration 5.13 Auxiliary Trip Circuit

Parameter settings:

- Parameter 3-3 Input A Function.

- Select *Input Trip (N/O)* assigns input A to auxiliary trip (N/O)-function.
- *Parameter 3-4 Input A Name.*
 - Select a name, for example Low Pressure - assigns a name to input A.
- *Parameter 3-8 Remote Reset Logic.*
 - Select as required, for example Normally Closed - the input behaves like a normally closed contact.

5.12 DC Brake with External Zero-speed Sensor

5

For loads varying between braking cycles, there are benefits in using an external zero-speed sensor to interface with the MCD 500 for brake shut-off. This control method ensures that the MCD 500 braking always shuts off when the motor has reached a standstill, thus avoiding unnecessary motor heating.

Illustration 5.14 shows how to use a zero-speed sensor with the MCD 500 to turn off the brake function at motor standstill. The zero-speed sensor (-A2) is often referred to as an under-speed detector. Its internal contact is open at zero-speed and closed at any speed above zero-speed. Once the motor has reached a standstill, terminals 11 and 16 open, and the soft starter is disabled. When the next start command is given, that is next application of K10, terminals 11 and 16 close, and the soft starter is enabled.

Operate the MCD 500 in remote mode and set *parameter 3-3 Input A Function* to *Starter disable*.

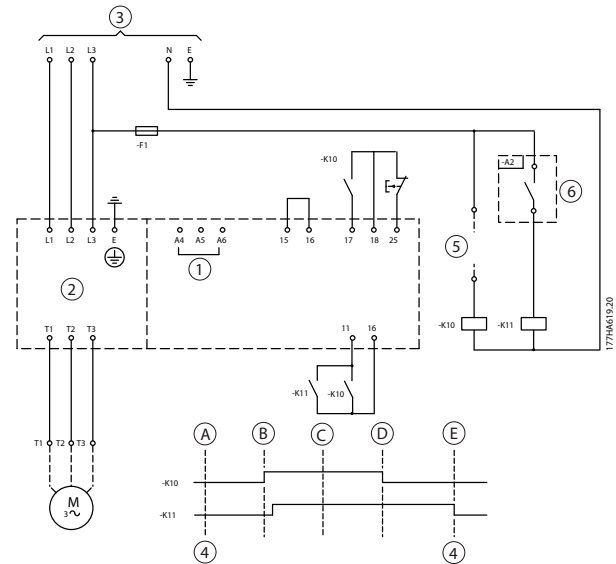

1	Control voltage	15, 16	Start
2	Motor terminals	17, 18	Stop
3	3-phase supply	25, 18	Reset
4	Starter disable (shown on soft starter display)	A	Off (ready)
5	Start signal (2, 3, or 4-wire)	B	Start
6	Zero-speed detect	C	Run
7	Zero-speed sensor	D	Stop
		E	Zero speed

Illustration 5.14 Turning Off Brake Function at Standstill with Zero-speed Sensor

For details on configuring DC Brake, see *chapter 5.4.5 Brake*.

CAUTION

When using DC brake, connect the mains supply to the soft starter (input terminals L1, L2, L3) in positive phase sequence. Then set *parameter 2-1 Phase Sequence* to *Positive only*.

5.13 Soft Braking

For high inertia loads, the MCD 500 can be configured for soft braking.

In this application, the MCD 500 is employed with forward run and braking contactors. When the soft starter receives a start signal (pushbutton S1), it closes the forward run contactor (K1) and controls the motor according to the programmed primary motor settings.

When the soft starter receives a stop signal (pushbutton S2), it opens the forward run contactor (K1) and closes the braking contactor (K2) after a delay of approximately 2–3 s (K1T). K12 is also closed to activate the secondary motor settings, which are user-programmed for the desired stopping performance characteristics.

When motor speed approaches zero, the external zero-speed sensor (A2) stops the soft starter and opens the braking contactor (K2).

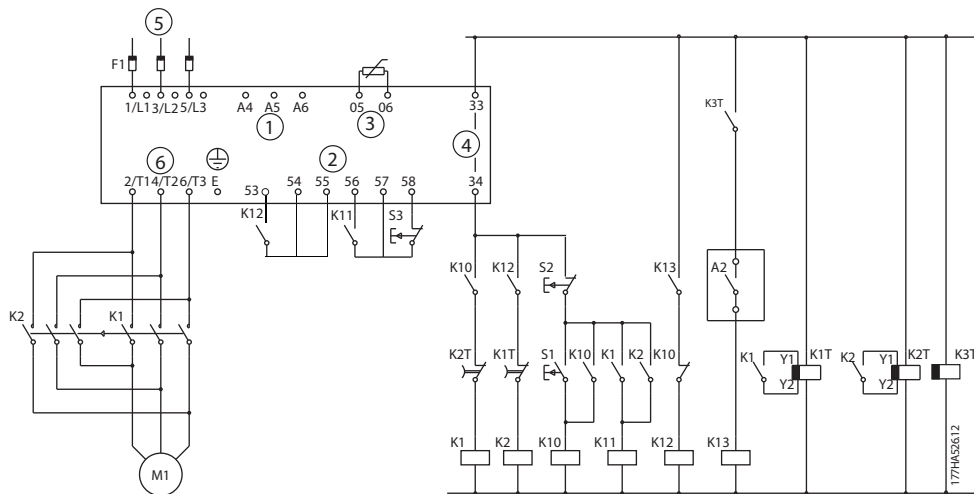

1	Control voltage (model dependent)	K10	Run relay
2	Remote control inputs	K11	Start relay
3	Motor thermistor input (PTC only)	K12	Brake relay
4	Relay outputs	K13	Zero-speed detector relay
5	3-phase supply	K1	Line contactor (Run)
6	Motor terminals	K2	Line contactor (Brake)
A2	Zero-speed sensor	K1T	Run delay timer
S1	Start contact	K2T	Brake delay timer
S2	Stop contact	K3T	Zero-speed detector delay timer
S3	Reset contact		

Illustration 5.15 Soft Braking Configuration

Parameter settings:

- *Parameter 3-3 Input A Function*
 - Select *Motor Set Select* - assigns input A for motor set selection.
 - Set starting performance characteristics using the primary motor set (parameter group 1 *Primary Motor Settings*).

- Set braking performance characteristics using the secondary motor settings (parameter group 7 *Secondary Motor Set*).
- *Parameter 4-7 Relay C Function.*
 - Select *Trip* - assigns trip function to output relay C.

NOTICE

If the soft starter trips on supply frequency (*parameter 16-5 Frequency*) when the braking contactor K2 opens, modify the setting of *parameters 2-8 to 2-10*.

5.14 Two-speed Motor

The MCD 500 can be configured for control of dual speed Dahlander type motors, using a high-speed contactor (K1), low-speed contactor (K2), and a star contactor (K3).

NOTICE

Pole amplitude modulated (PAM) motors alter the speed by effectively changing the stator frequency using external winding configuration. Soft starters are not suitable for use with this type of 2-speed motor.

When the soft starter receives a high-speed start signal, it closes the high-speed contactor (K1) and star contactor (K3). Then it controls the motor according to the primary motor settings (*parameters 1-1 to 1-16*).

When the soft starter receives a low-speed start signal, it closes the low-speed contactor (K2). This action closes input A and the soft starter controls the motor according to the secondary motor settings (*parameters 7-1 to 7-16*).

NOTICE

If the soft starter trips on supply frequency (*16-5 Frequency*) when the high-speed start signal (7) is removed, modify the setting of *parameters 2-8 to 2-10*.

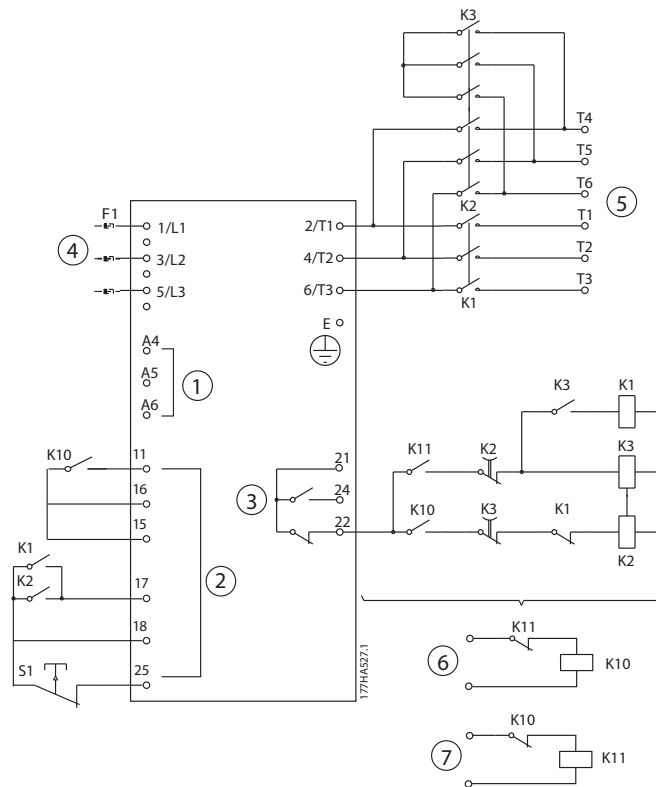

1	Control voltage	6	Remote low-speed start input	K2	Line contactor (low-speed)
2	Remote control inputs	7	Remote high-speed start input	K3	Star contactor (high-speed)
3	Relay outputs	K10	Remote start relay (low-speed)	S1	Reset contact
4	3-phase supply	K11	Remote start relay (high-speed)	21, 22, 24	Relay output B
5	Motor terminals	K1	Line contactor (high-speed)		

Illustration 5.16 Two-speed Motor Configuration

NOTICE

Contactors K2 and K3 must be mechanically interlocked.

Parameter settings:

- *Parameter 3-3 Input A Function.*
 - Select *Motor Set Select* - assigns input A for motor set selection.
 - Set high-speed performance characteristics using *parameters 1-1 to 2-9.*
 - Set low-speed performance characteristics using *parameters 7-1 to 7-16.*
- *Parameter 4-4 Relay B Function.*
 - Select *Trip* - assigns trip function to relay output B.

NOTICE

If the soft starter trips on supply frequency (*parameter 16-5 Frequency*) when the high-speed signal (7) is removed, modify the settings of *parameters 2-9 to 2-10.*

6 Operation

6.1 Control Methods

The MCD 500 can be controlled:

- Via the control keys on the LCP (local control).
- Via the remote inputs (remote control).
- Via the serial communication network.
- Local control is only available in *Hand On* mode.
- Remote control is only available in *Auto On* mode.
- Control via the serial communication network is always disabled in *Hand On* mode. Enable/disable start/stop commands via the serial network in *Auto On* mode by changing the setting of *3-2 Comms in Remote*.

The MCD 500 can also be configured to auto-start or auto-stop. Auto-start/stop operation is only available in *Auto On* mode. In *Hand On* mode, the soft starter ignores any auto-start/stop setting. To configure auto-start/stop operation, set *parameters 5-1 to 5-4*.

To switch between *Hand On* and *Auto On* modes, press the keys on the LCP.

- [Hand On]: Start the motor and enter *Hand On* mode.
- [Off]: Stop the motor and enter *Hand On* mode.
- [Auto On]: Set the soft starter to *Auto On* mode.
- [Reset]: Reset a trip (*Hand On* mode only).

The MCD 500 can also be set to allow local control only or remote control only, using *parameter 3-1 Local/Remote*.

If *parameter 3-1 Local/Remote* is set to *Remote Control Only*, the [Off] key is disabled. Stop the motor by remote control or via the serial communication network.

	Hand On mode	Auto On mode
To soft start the motor.	Press [Hand On] on the LCP.	Activate the <i>Start remote</i> input.
To stop the motor.	Press [Off] on the LCP.	Activate the <i>Stop remote</i> input.
To reset a trip on the soft starter.	Press [Reset] on the LCP.	Activate the <i>Reset remote</i> input.
Auto start/stop operation.	Disabled.	Enabled.

Table 6.1 Start, Stop, and Reset in Hand On Mode and Auto On Mode

To stop the motor with a coast to stop, regardless of the setting in *parameter 1-10 Stop Mode*, press [Off] and [Reset] at the same time. The soft starter removes power from the motor and opens the main contactor, and the motor coasts to stop.

NOTICE

Brake and jog functions operate only with in-line connected motors (see *chapter 5.6 Inside Delta Operation*).

6.2 Operation and LCP

6.2.2 The LCP

6.2.1 Operating Modes

In *Hand On* mode:

- To soft start the motor, press [Hand On] on the LCP
- To stop the motor, press [Off] on the LCP
- To reset a trip on the soft starter, press [Reset] on the LCP
- To stop the motor with a coast to stop, regardless of the setting of *parameter 1-10 Stop mode*, press [Off] and [Reset] at the same time. The soft starter removes power from the motor and opens the main contactor, and then the motor coasts to stop.

In *Auto On* mode:

- To soft start the motor, activate the *Start* remote input.
- To stop the motor, activate the *Stop* remote input.
- To reset a trip on the soft starter, activate the *Reset* remote input.

NOTICE

Brake and jog functions operate only with in-line connected motors (see *chapter 4.3.3 Inside Delta Installation*).

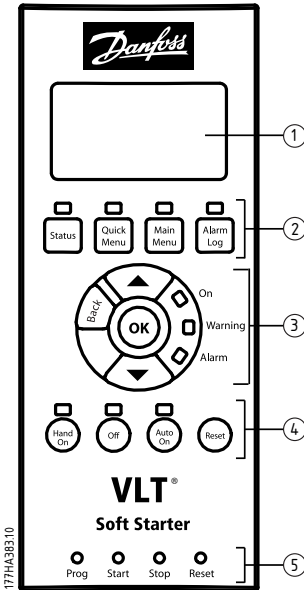

1	4-line display for status and programming details.
2	Display control keys: [Status]: Returns to the status displays [Quick Menu]: Opens the Quick Menu [Main Menu]: Opens the Main Menu [Alarm Log]: Opens the Alarm Log
3	Menu navigation keys: [Back]: Exits the menu or parameter, or cancel a parameter change [OK]: Enters a menu or parameter, or save a parameter change [▲]/[▼]: <ul style="list-style-type: none"> • Scroll to the next or previous menu or parameter. • Change the setting of the current parameter. • Scroll through the status screens.
4	Soft starter local control keys: [Hand On]: Starts the motor and enter local control mode. [Off]: Stops the motor (only active in <i>Hand On</i> mode). [Auto On]: Sets the soft starter to <i>Auto On</i> mode. [Reset]: Resets a trip (<i>Hand On</i> mode only).
5	Remote input status LEDs.

Illustration 6.1 LCP Layout

6.3 Remote Mounted LCP

A remote-mounted LCP can be installed with the MCD 500. The control panel LCP 501 can be mounted up to 3 m away from the soft starter, for control and monitoring.

The soft starter can be controlled and programmed from either the remote LCP or the LCP on the soft starter. Both displays show the same information.

The remote LCP also allows parameter settings to be copied between soft starters.

6.3.1 Synchronising the LCP and the Soft Starter

The DB9 cable can be connected/disconnected from the LCP while the soft starter runs.

The first time an LCP is plugged into a soft starter, the soft starter copies its parameter settings to the LCP.

New display detected

If the LCP has previously been used with an MCD 500, select whether to copy the parameters from the LCP to the soft starter, or from the soft starter to the LCP.

To select the required option:

1. Press the [▲] and [▼] keys.

A dotted line surrounds the selected option.

2. Press [OK] to proceed with the *Copy Parameters* selection.
 - 2a Display to Starter.
 - 2b Starter to Display.

Copy parameters
Display to starter
Starter to display

NOTICE

If the parameter software version in the LCP is different from the software version of the soft starter, only *Starter to Display* is available.

NOTICE

While the LCP synchronises, only the [▲], [▼], [OK], and [Off] keys are enabled.

NOTICE

The LCP can be removed or replaced while the soft starter runs. It is not necessary to remove mains or control voltage.

6.4 Welcome Screen

When control power is applied, the soft starter displays the welcome screen

Ready	S1
Welcome 1.05/2.0/1.13 MCD5-0053-T5-G1-CV2	

Third display line: Software versions for remote LCP, control software, model software.

Fourth display line: Product model number.

NOTICE

The LCP version is only displayed if a remote LCP 501 is connected when control power is applied. If no remote LCP is present, only the control software and model software versions are displayed.

6.5 Local Control Keys

If *parameter 3-1 Local/Remote* is set to *LCL/RMT Anytime* or *LCL/RMT When OFF*, the [Hand On] and [Auto On] keys are always active. If the soft starter is in *Auto On* mode, pressing [Hand On] enters *Hand On* mode and starts the motor.

If *parameter 3-1 Local/Remote* is set to *Remote Control Only*, the [Off] key is disabled. Stop the motor by remote control or via the serial communication network.

6.6 Displays

The LCP displays a wide range of performance information about the soft starter. Press [Status] to access the status display screens, then press [▲] and [▼] to select the information to display. To return to the status screens from within a menu, press [Back] repeatedly, or press [Status].

Available status information:

- Temperature monitoring.
- Programmable screen (see *parameters 8-2 to 8-5*).
- Current.
- Frequency.
- Motor power.
- Last start information.
- Date and time.
- SCR Conduction bar-graph.

- Performance graphs.

NOTICE

Screens shown here are with the default settings.

6.6.1 Temperature Monitoring Screen (S1)

The temperature screen shows the temperature of the motor as a percentage of total thermal capacity. It also shows which motor data set is in use.

The temperature monitoring screen is the default status screen.

Ready			S1
MS1	000.0A	000.0kW	
	Primary Motor Set		
M1 000%			

6.6.2 Programmable Screen (S2)

The user-programmable screen of the soft starter can be configured to show the most important information for the particular application. Use *parameters 8-2 to 8-5* to select which information to display.

Ready			S2
MS1	000.0A	000.0kW	
	-- pf		
00000 hrs			

6.6.3 Average Current (S3)

The average current screen shows the average current of all 3 phases.

Ready			S3
MS1	000.0A	000.0kW	
	0.0A		

6.6.4 Current Monitoring Screen (S4)

The current screen shows real-time line current on each phase.

Ready			S4
MS1	000.0A	000.0kW	
	Phase currents		
000.0A	000.0A	000.0A	

6.6.5 Frequency Monitoring Screen (S5)

The frequency screen shows the mains frequency as measured by the soft starter.

Ready			S5
MS1	000.0A	000.0kW	
	00.0Hz		

6.6.6 Motor Power Screen (S6)

The motor power screen shows motor power (kW, hp, and kVA) and power factor.

Ready			S6
MS1	000.0A	000.0kW	
		0000HP	
		0000kVA	-- - pf

6.6.7 Last Start Information (S7)

The last start information screen shows details of the most recent successful start:

- Start duration, (s).
- Maximum start current drawn (as a percentage of motor full load current).
- Calculated rise in motor temperature.

Ready			S7
MS1	000.0A	000.0kW	
Last start		000 s	
000% FLC		ΔTemp 0%	

6.6.8 Date and Time (S8)

The date/time screen shows the current system date and time (24-hour format). For details on setting the date and time, see *chapter 9.1 Set Date and Time*.

Ready			S8
MS1	000.0A	000.0kW	
	YYYY MMM DD		
	HH:MM:SS		

6.6.9 SCR Conduction Bargraph

The SCR conduction bargraph shows the level of conduction on each phase.



Illustration 6.2 Bargraph

6

6.6.10 Performance Graphs

The MCD 500 can display real-time performance information for:

- Current.
- Motor temperature.
- Motor kW.
- Motor kVA.
- Motor power factor.

The newest information is displayed at the right-hand edge of the screen. Older data is not stored. To allow past performance to be analysed, the graph can also be paused. To pause or unpaue the graph, press and hold [OK] for more than 0.5 s.

NOTICE

The soft starter does not collect data while the graph is paused. When graphing resumes, a small gap is shown between the old data and the new data.

7 Programming

It is possible to access the programming menus at any time, including while the soft starter is running. All changes take effect immediately.

7.1 Access Control

A 4-digit security access code protects critical parameters (parameter group *15 Restricted Parameters* and higher), preventing unauthorised users from viewing or modifying parameter settings.

If attempts are made to enter a restricted parameter group, the LCP prompts for an access code. The access code is requested once for the programming session, and authorisation continues until closing the menu.

To enter the access code:

1. Press [Back] and [OK] to select a digit.
2. Press [▲] and [▼] to change the value.
3. When all 4 digits match the access code, press [OK].

The LCP displays an acknowledgement message before continuing.

Enter Access Code	
####	
	OK
Access Allowed	
SUPERVISOR	

To change the access code, use *parameter 15-1 Access Code*.

NOTICE

The security access code also protects the protection simulation and output simulation. The counters and thermal model reset can be viewed without entering an access code, but an access code must be entered to reset.

The default access code is 0000.

To prevent users from altering parameter settings, lock the menus. The adjustment lock can be set to allow *Read & Write*, *Read Only*, or *No Access* in *15-2 Adjustment Lock*.

If a user attempts to change a parameter value or access the Main Menu when the adjustment lock is active, an error message is displayed:

Access Denied
Adj Lock is On

7.2 Quick Menu

[Quick Menu] provides access to the menus for setting up the soft starter for simple applications.

7.2.1 Quick Set-up

Quick set-up provides access to commonly used parameters, allowing to configure the soft starter as required for the application. For details of individual parameters, see *chapter 8 Parameter Descriptions*.

1	Primary Mtr Set
1-1	Motor FLC
1-3	Start Mode
1-4	Current Limit
1-5	Initial Current
1-6	Start Ramp Time
1-9	Excess Start Time
1-10	Stop Mode
1-11	Stop Time
2	Protection
2-1	Phase Sequence
2-4	Undercurrent
2-5	Undercurrent Dly
2-6	Inst Overcurrent
2-7	Inst Overcurrent Dly
3	Inputs
3-3	Input A Function
3-4	Input A Name
3-5	Input A Trip
3-6	Input A Trip Dly
3-7	Input A Initial Dly
4	Outputs
4-1	Relay A Function
4-2	Relay A On Delay
4-3	Relay A Off Delay
4-4	Relay B Function
4-5	Relay B On Delay
4-6	Relay B Off Delay
4-7	Relay C Function
4-8	Relay C On Delay
4-9	Relay C Off Delay
4-10	Low Current Flag
4-11	High Current Flag
4-12	Motor Temp Flag
5	Start/Stop Timers

1	Primary Mtr Set
5-1	Auto-Start Type
5-2	Auto-Start Time
5-3	Auto-Stop Type
5-4	Auto-Stop Time
8	Display
8-1	Language
8-2	User Scrn Top L
8-3	User Scrn Top R
8-4	User Scrn Btm L
8-5	User Scrn Btm R

Table 7.1 Parameters in the Quick Set-up Menu

7.2.2 Application Set-up Examples

The application set-ups menu makes it easy to configure the soft starter for common applications. The soft starter selects the parameters relevant to the application and suggests a typical setting. Each parameter can be adjusted to suit the exact requirements.

On the display, the highlighted values are suggested values. The values indicated by a ► are the loaded values.

Always set 1-1 Motor FLC to match the motor nameplate full load current. The suggested value for motor FLC is the minimum FLC of the soft starter.

Pump centrifugal

Motor Full Load Current	
Start mode	Adaptive control
Adaptive start profile	Early acceleration
Start ramp time	10 s
Stop mode	Adaptive control
Adaptive stop profile	Late deceleration
Stop time	15 s

Table 7.2 Suggested Values for Centrifugal Pump Applications

Pump submersible

Motor Full Load Current	
Start Mode	Adaptive Control
Adaptive Start Profile	Early Acceleration
Start Ramp Time	5 s
Stop Mode	Adaptive Control
Adaptive Stop Profile	Late Deceleration
Stop Time	5 s

Table 7.3 Suggested Values for Submersible Pump Applications

Fan damped

Motor Full Load Current	
Start Mode	Constant Current
Current Limit	350%

Table 7.4 Suggested Values for Damped Fan Applications

Fan undamped

Motor Full Load Current	
Start Mode	Adaptive Control
Adaptive Start Profile	Constant Acceleration
Start Ramp Time	20 s
Excess Start Time	30 s
Locked Rotor Time	20 s

Table 7.5 Suggested Values for Undamped Fan Applications

Compressor screw

Motor Full Load Current	
Start Mode	Constant Current
Start Ramp Time	5 s
Current Limit	400%

Table 7.6 Suggested Values for Compressor Screw Applications

Compressor recip

Motor Full Load Current	
Start Mode	Constant Current
Start Ramp Time	10 s
Current Limit	450%

Table 7.7 Suggested Values for Compressor Recip Applications

Conveyor

Motor Full Load Current	
Start Mode	Constant Current
Start Ramp Time	5 s
Current Limit	400%
Stop Mode	Adaptive Control
Adaptive Stop Profile	Constant Deceleration
Stop Time	10 s

Table 7.8 Suggested Values for Conveyor Applications

Crusher rotary

Motor Full Load Current	
Start Mode	Constant Current
Start Ramp Time	10 s
Current Limit	400%
Excess Start Time	30 s
Locked Rotor Time	20 s

Table 7.9 Suggested Values for Crusher Rotary Applications

Crusher jaw

Motor Full Load Current	
Start Mode	Constant Current
Start Ramp Time	10 s
Current Limit	450%
Excess Start Time	40 s
Locked Rotor Time	30 s

Table 7.10 Suggested Values for Crusher Jaw Applications

7.2.3 Loggings

To view performance information in real-time graphs, enter the *Loggings* menu.

- Current (%FLC).
- Motor Temp (%).
- Motor kW (%).
- Motor kVA (%).
- Motor pf.

The newest information is displayed at the right-hand edge of the screen. The graph can be paused to analyse data by pressing and holding the [OK] key. To restart the graph, press and hold [OK].

7.3 Main Menu

[Main Menu] provides access to menus for setting up the soft starter for advanced applications and for monitoring performance.

7.3.1 Parameters

Parameters allow viewing and changing all programmable parameters that control how the soft starter operates.

To open *Parameters*, press [Main Menu] then select *Parameters*.

Navigating through parameters

- To scroll through parameter groups, press [▲] or [▼].
- To view the parameters in a group, press [OK].
- To return to the previous level, press [Back].
- To close *Parameters*, press the [Back].

Changing a parameter value

- Scroll to the appropriate parameter and press [OK] to enter edit mode.
- To alter the parameter setting, press [▲] and [▼].
- To save changes, press [OK]. The setting shown on the display is saved and the LCP returns to the parameter list.
- To cancel changes, press [Back]. The LCP returns to the parameter list without saving changes.

7.3.2 Parameter Shortcut

The MCD 500 also includes a parameter shortcut, which gives direct access to a parameter within the *Parameters* menu.

- To access the parameter shortcut, press [Main Menu] for 3 s.
- Press [▲] or [▼] to select the parameter group.
- Press [OK] or [Back] to move the cursor.
- Press [▲] or [▼] to select the parameter number.

Parameter shortcut
Please enter a Parameter number 01-01

7.3.3 Parameter List

1	Primary Mtr Set	4	Outputs	7-12	Adaptv Ctrl Gain-2
1-1	Motor FLC	4-1	Relay A Function	7-13	Adaptv Start Prof-2
1-2	Locked Rotor Time	4-2	Relay A On Delay	7-14	Adaptv Stop Prof-2
1-3	Start Mode	4-3	Relay A Off Delay	7-15	Brake Torque-2
1-4	Current Limit	4-4	Relay B Function	7-16	Brake Time-2
1-5	Initial Current	4-5	Relay B On Delay	8	Display
1-6	Start Ramp Time	4-6	Relay B Off Delay	8-1	Language
1-7	Kick start Level	4-7	Relay C Function	8-2	User Scrn Top L
1-8	Kick start Time	4-8	Relay C On Delay	8-3	User Scrn Top R
1-9	Excess Start Time	4-9	Relay C Off Delay	8-4	User Scrn Btm L
1-10	Stop Mode	4-10	Low Current Flag	8-5	User Scrn Btm R
1-11	Stop Time	4-11	High Current Flag	8-6	Graph Timebase
1-12	Adaptv Control Gain	4-12	Motor Temp Flag	8-7	Graph Max Adj
1-13	Adaptv Start Profile	4-13	Analog Output A	8-8	Graph Min Adj
1-14	Adaptv Stop Profile	4-14	Analog A Scale	8-9	Mains Ref Volt
1-15	Brake Torque	4-15	Analog A Max Adj	15	Restrict Paramtr
1-16	Brake Time	4-16	Analog A Min Adj	15-1	Access Code
2	Protection	5	Start/Stop Timers	15-2	Adjustment Lock
2-1	Phase Sequence	5-1	Auto-Start Type	15-3	Emergency Run
2-2	Current Imbalance	5-2	Auto-Start Time	15-4	Current Calibrat
2-3	Current Imbal Dly	5-3	Auto-Stop Type	15-5	Main Cont Time
2-4	Undercurrent	5-4	Auto-Stop Time	15-6	Bypass Cont Time
2-5	Undercurrent Dly	6	Auto-Reset	15-7	Motor Connection
2-6	Inst Overcurrent	6-1	Auto-Reset Action	15-8	Jog Torque
2-7	Inst Ocrnt Dly	6-2	Maximum Resets	16	Protection Action
2-8	Frequency Check	6-3	Reset Dly Grp A & B	16-1	Motor Overload
2-9	Freq Variation	6-4	Reset Delay Grp C	16-2	Current Imbalance
2-10	Frequency Delay	7	Secondary Mtr Set	16-3	Undercurrent
2-11	Restart Delay	7-1	Motor FLC-2	16-4	Inst Overcurrent
2-12	Motor Temp Check	7-2	Lock Rotor Time-2	16-5	Frequency
3	Inputs	7-3	Start Mode-2	16-6	Heat sink Overtemp
3-1	Local/Remote	7-4	Current Limit-2	16-7	Excess Start Time
3-2	Comms in Remote	7-5	Initial Crnt-2	16-8	Input A Trip
3-3	Input A Function	7-6	Start Ramp-2	16-9	Motor Thermistor
3-4	Input A Name	7-7	Kick start Lvl-2	16-10	Starter Comms
3-5	Input A Trip	7-8	Kick start Time-2	16-11	Network Comms
3-6	Input A Trip Dly	7-9	Excess Strt Time-2	16-12	Battery/Clock
3-7	Input A Initial Dly	7-10	Stop Mode-2	16-13	Low Control Volts
3-8	Remote Reset Logic	7-11	Stop Time-2		

8 Parameter Descriptions

8.1 Primary Motor Settings

NOTICE

Default settings are marked with *.

The parameters in *Primary Motors Settings* configure the soft starter to match the connected motor. These parameters describe the operating characteristics of the motor and allow the soft starter to model the motor temperature.

NOTICE

Parameter 1-2 *Locked Rotor Time* determines the trip current for motor overload protection. Its default setting provides motor overload protection:

- Class 10.
- Trip current 105% of FLA, or equivalent.

1-1 Motor FLC

Option: **Function:**

Model dependent	Matches the soft starter to the connected motor full load current. Set to the full load current (FLC) rating shown on the motor nameplate. NOTICE The setting for this parameter sets the basis for calculation of all current-based protection settings.
-----------------	--

1-2 Locked Rotor Time

Range: **Function:**

10 s*	[0:01–2:00 (min:s)]	Sets the maximum length of the time the motor can sustain locked rotor current from cold before reaching its maximum temperature. Set according to the motor datasheet.
-------	---------------------	---

1-3 Start Mode

Option: **Function:**

		Selects the soft start mode. See <i>chapter 5.3 Starting Modes</i> for more details.
Constant Current*		
Adaptive Control		

1-4 Current Limit

Range: **Function:**

350%*	[100–600% FLC]	Sets the current limit for constant current and current ramp soft starting as a percentage of motor full load current. See <i>chapter 5.3 Starting Modes</i> for more details.
-------	----------------	--

1-5 Initial Current

Range: **Function:**

350%*	[100–600% FLC]	Sets the initial start current level for current ramp starting, as a percentage of motor full load current. Set so that the motor begins to accelerate immediately after a start is initiated. If current ramp starting is not required, set the initial current equal to the current limit. See <i>chapter 5.3 Starting Modes</i> for more details.
-------	----------------	--

1-6 Start Ramp Time

Range: **Function:**

10 s*	[1–180 s]	Sets the total start time for an adaptive control start or the ramp time for current ramp starting (from the initial current to the current limit). See <i>chapter 5.3 Starting Modes</i> for more details.
-------	-----------	---

1-7 Kick Start Level

Range: **Function:**

500%*	[100%–700% FLC]	Sets the level of the kick start current. CAUTION Kick start subjects the mechanical equipment to increased torque levels. Ensure the motor, load, and couplings can handle the additional torque before using this feature.
-------	-----------------	---

1-8 Kick Start Time

Range: **Function:**

0000 ms*	[0–2000 ms]	Sets the kick start duration. A setting of 0 disables kick start. See <i>chapter 5.3 Starting Modes</i> for more details. CAUTION Kick start subjects the mechanical equipment to increased torque levels. Ensure the motor, load and couplings can handle the additional torque before using this feature.
----------	-------------	--

1-9 Excess Start Time

Range: **Function:**

		Excess start time is the maximum time the MCD 500 attempts to start the motor. If the motor does not reach full speed within the programmed limit, the soft starter trips. Set for a period slightly longer than required for a
--	--	---

1-9 Excess Start Time		
Range:	Function:	
		normal healthy start. A setting of 0 disables excess start time protection.
20 s*	[0:00–4:00 (min:s)]	Set as required.

1-10 Stop Mode		
Option:	Function:	
		Selects the stop mode. See <i>chapter 5.4 Stopping Modes</i> for more details.
Coast to Stop*		
TVR Soft Stop		
Adaptive Control		
Brake		

1-11 Stop Time		
Range:	Function:	
0 s*	[0:00–4:00 (min:s)]	Sets the time for soft stopping the motor using timed voltage ramp or adaptive control. If a main contactor is installed, the contactor must remain closed until the end of the stop time. To control the main contactor, use a programmable output configured to <i>Run</i> . Sets the total stopping time when using brake. See <i>chapter 5.4 Stopping Modes</i> for more details.

1-12 Adaptive Control Gain		
Range:	Function:	
75%*	[1–200%]	Adjusts the performance of adaptive control. This setting affects both starting and stopping control. NOTICE Leave the gain setting at the default level unless adaptive control performance is not satisfactory. If the motor accelerates or decelerates too quickly at the end of a start or stop, increase the gain setting by 5–10%. If the motor speed fluctuates during starting or stopping, decrease the gain setting slightly.

1-13 Adaptive Start Profile		
Option:	Function:	
		Selects which profile the soft starter uses for an adaptive control soft start. See <i>chapter 5.4 Stopping Modes</i> for more details.
Early Acceleration		
Constant Acceleration*		
Late Acceleration		

1-14 Adaptive Stop Profile		
Option:	Function:	
		Selects which profile the soft starter uses for an adaptive control soft stop. See <i>chapter 5.4 Stopping Modes</i> for more details.
Early Deceleration		
Constant Deceleration*		
Late Acceleration		

8.1.1 Brake

Brake uses DC injection to slow the motor actively. See *chapter 5.4 Stopping Modes* for more details.

1-15 Brake Torque		
Range:	Function:	
20%*	[20–100%]	Sets the amount of brake torque the soft starter uses to slow the motor.

1-16 Brake Time		
Range:	Function:	
1 s*	[1–30 s]	Sets the duration for DC injection during a braking stop. NOTICE This parameter is used with <i>parameter 1-11 Stop Time</i> . See <i>chapter 8.1.1 Brakechapter 5.4 Stopping Modes</i> for details.

8.2 Protection

2-1 Phase Sequence		
Option:	Function:	
		Selects which phase sequences the soft starter allows at a start. During its pre-start checks, the soft starter examines the sequence of the phases at its input terminals. If the actual sequence does not match the selected option, the soft starter trips.
Any sequence*		
Positive only		
Negative only		

8.2.1 Current Imbalance

If the currents on the 3 phases vary from each other by more than a specified amount, the soft starter can be configured to trip. The imbalance is calculated as the difference between the highest and lowest currents on all 3 phases, as a percentage of the highest current.

Current imbalance detection is desensitised by 50% during starting and soft stopping.

2-2 Current Imbalance

Range:	Function:
30%* [10–50%]	Sets the trip point for current imbalance protection.

2-3 Current Imbalance Delay

Range:	Function:
3 s* [0:00–4:00 (min:s)]	Slows the response of the soft starter to current imbalance, avoiding trips due to momentary fluctuations.

8.2.2 Undercurrent

If the average current of all 3 phases drops below a specified level while the motor is running, the soft starter can be configured to trip.

2-4 Undercurrent

Range:	Function:
20%* [0–100%]	Sets the trip point for undercurrent protection, as a percentage of motor full load current. Set to a level between the normal motor working range and the motor magnetising (no load) current (typically 25–35% of full load current). A setting of 0% disables undercurrent protection.

2-5 Undercurrent Delay

Range:	Function:
5 s* [0:00–4:00 (min:s)]	Slows the response of the soft starter to undercurrent, avoiding trips due to momentary fluctuations.

8.2.3 Instantaneous Overcurrent

If the average current of all 3 phases exceeds a specified level while the motor is running, the soft starter can be configured to trip.

2-6 Instantaneous Overcurrent

Range:	Function:
400%* [80–600% FLC]	Sets the trip point for instantaneous overcurrent protection, as a percentage of motor full load current.

2-7 Instantaneous Overcurrent Delay

Range:	Function:
0 s* [0:00–1:00 (min:s)]	Slows the response of the soft starter to overcurrent, avoiding trips due to momentary overcurrent events.

8.2.4 Frequency Trip

The soft starter monitors mains frequency throughout operation, and can be configured to trip if the frequency varies beyond a specified tolerance.

2-8 Frequency Check

Option:	Function:
	Determines when the soft starter monitors for a frequency trip.
Do not Check	
Start Only	
Start/Run*	
Run Only	

2-9 Frequency Variation

Option:	Function:
	Selects the soft starter tolerance for frequency variation.
± 2 Hz	
± 5 Hz*	
± 10 Hz	
± 15 Hz	

2-10 Frequency Delay

Range:	Function:
1 s* [0:01–4:00 (min:s)]	Slows the response of the soft starter to frequency disturbances, avoiding trips due to momentary fluctuations. NOTICE If the mains frequency drops below 35 Hz or rises above 75 Hz, the soft starter trips immediately.

2-11 Restart Delay

Range:	Function:
10 s* [00:01–60:00 (min:s)]	The soft starter can be configured to force a delay between the end of a stop and the beginning of the next start. During the restart delay, the display shows the time remaining until another start can be attempted. NOTICE The restart delay is measured from the end of each stop. Changes to the restart delay setting take effect after the next stop.

2-12 Motor Temperature Check

Option:	Function:
	Selects whether the soft starter verifies that the motor has sufficient thermal capacity for a successful start. The soft starter compares the calculated motor temperature with the temperature rise from the last motor start. The soft starter only operates if the motor is cool enough to start successfully.
Do not Check*	
Check	

8.3 Inputs

3-1 Local/Remote

Option: **Function:**

	Selects when the [Auto On] and [Hand On] can be used to switch to <i>Hand On</i> or <i>Auto On</i> modes.
Lcl/Rmt anytime*	Change between local and remote control at any time.
Local Control Only	All remote inputs are disabled.
Remote Control Only	[Hand On] and [Auto On] are disabled.

3-2 Comms in Remote

Option: **Function:**

	Selects whether the soft starter accepts start and stop commands from the serial communication network when in <i>Remote</i> mode. Commands that are always enabled: <ul style="list-style-type: none"> • <i>Force Comms Trip</i> • <i>Local/Remote Control</i> • <i>Test Start</i> • <i>Reset</i>
Disable Ctrl in RMT	
Enable Ctrl in RMT*	

3-3 Input A Function

Option: **Function:**

	Selects the function of input A.
Motor Set Select*	The soft starter can be configured with 2 separate sets of motor data. The primary motor data is programmed using <i>parameters 1-1 to 1-16</i> . The secondary motor data is programmed using <i>parameters 7-1 to 7-16</i> . To use the secondary motor data, set this parameter to <i>Motor Set Select</i> and close 11, 16 before giving a start command. The soft starter checks which motor data to use at a start, and uses that motor data for the entire start/stop cycle.
Input Trip (N/O)	Input A can be used to trip the soft starter. When this parameter is set to <i>Input Trip (N/O)</i> , a closed circuit across 11, 16 trips the soft starter (<i>Parameters 3-5 to 3-7</i>).
Input Trip (N/C)	When this parameter is set to <i>Input Trip (N/C)</i> , an open circuit across 11, 16 trips the soft starter (<i>Parameters 3-5 to 3-7</i>).
Local/Remote Select	Input A can be used to select between local and remote control, instead of using the LCP keys. When the input is open, the soft starter is in local mode and can be controlled via the LCP. When the input is closed, the soft starter is in

3-3 Input A Function

Option: **Function:**

	remote mode. The [Hand On] and [Auto On] keys are disabled, and the soft starter ignores any local/remote select command from the serial communications network. To use Input A to select between local and remote control, set <i>parameter 3-1 Local/Remote</i> to <i>LCL/RMT Anytime</i> .
Emergency Run	In emergency run, the soft starter continues to run until stopped, ignoring all trips and warnings (see <i>parameter 15-3 Emergency Run</i> for details). Closing the circuit across 11, 16 activates emergency run. Opening the circuit ends emergency run and the soft starter stops the motor.
Starter disable	The soft starter can be disabled via the control inputs. An open circuit across terminals 11 and 16 disables the soft starter. The soft starter does not respond to start commands. If running, the soft starter allows the motor to coast to stop, ignoring the soft stop mode set in <i>parameter 1-10 Stop Mode</i> . When the circuit across 11, 16 is opened, the soft starter allows the motor to coast to stop.
Jog Forward	Activates jog operation in a forward direction (operates only in Remote mode).
Jog Reverse	Activates jog operation in reverse direction (operates only in Remote mode).

3-4 Input A Name

Option: **Function:**

	Selects a message for the LCP to display when input A is active.
Input Trip *	
Low Pressure	
High Pressure	
Pump Fault	
Low Level	
High Level	
No Flow	
Starter Disable	
Controller	
PLC	
Vibration Alarm	

3-5 Input A Trip

Option: **Function:**

	Selects when an input trip can occur.
Always Active*	A trip can occur at any time when the soft starter is receiving power.
Operating Only	A trip can occur while the soft starter is running, stopping, or starting.
Run Only	A trip can only occur while the soft starter is running.

3-6 Input A Trip Delay
Range: **Function:**

0 s*	[0:00–4:00 (min:s)]	Sets delay between the input activating and soft starter tripping.
------	---------------------	--

3-7 Input A Initial Delay
Range: **Function:**

0 s*	[00:00–30:00 (min:s)]	Sets a delay before an input trip can occur. The initial delay is counted from the time a start signal is received. The state of the input is ignored until the initial delay has elapsed.
------	-----------------------	--

3-8 Remote Reset Logic
Option: **Function:**

		Selects whether the remote reset input of the soft starter (terminals 25, 18) is normally open or normally closed.
	Normally Closed*	
	Normally Open	

8.4 Outputs

4-1 Relay A Function
Option: **Function:**

		Selects the function of Relay A (normally open).
	Off	Relay A is not used
	Main Contactor*	The relay closes when the soft starter receives a start command, and remains closed as long as the motor receives voltage.
	Run	The relay closes when the starter changes to run state.
	Trip	The relay closes when the starter trips.
	Warning	The relay closes when the starter issues a warning.
	Low Current Flag	The relay closes when the low current flag activates (<i>parameter 4-10 Low Current Flag</i>).
	High Current Flag	The relay closes when the high current flag activates (<i>parameter 4-11 High Current Flag</i>).
	Motor Temp Flag	The relay closes when the motor temperature flag activates (<i>parameter 4-12 Motor Temperature Flag</i>).

8.4.1 Relay A Delays

The soft starter can be configured to wait before opening or closing relay A.

4-2 Relay A On Delay
Range: **Function:**

0 s*	[0:00–5:00 (min:s)]	Sets the delay for closing relay A.
------	---------------------	-------------------------------------

4-3 Relay A Off Delay
Range: **Function:**

0 s*	[0:00–5:00 (min:s)]	Sets the delay for reopening relay A.
------	---------------------	---------------------------------------

8.4.2 Relays B and C

Parameters 4-4 to 4-9 configure the operation of relays B and C in the same way as *parameters 4-1 to 4-3* configure relay A. See *chapter 8.4.2 4-2 Relay A On Delay* and *chapter 8.4.2 4-3 Relay A Off Delay* for details.

- Relay B is a change-over relay.
- Relay C is normally open.

4-4 Relay B Function
Option: **Function:**

		Selects the function of relay B (change-over).
	Off	Relay B is not used
	Main Contactor	The relay closes when the soft starter receives a start command, and remains closed as long as the motor is receiving voltage.
	Run*	The relay closes when the soft starter changes to run state.
	Trip	The relay closes when the soft starter trips.
	Warning	The relay closes when the soft starter issues a warning.
	Low Current Flag	The relay closes when the low current flag activates (<i>parameter 4-10 Low Current Flag</i>).
	High Current Flag	The relay closes when the high current flag activates (<i>parameter 4-11 High Current Flag</i>).
	Motor Temp Flag	The relay closes when the motor temperature flag activates (<i>parameter 4-12 Motor Temperature Flag</i>).

4-5 Relay B On Delay
Range: **Function:**

0 s*	[0:00–5:00 (min:s)]	Sets the delay for closing relay B.
------	---------------------	-------------------------------------

4-6 Relay B Off Delay
Range: **Function:**

0 s*	[0:00–5:00 (min:s)]	Sets the delay for reopening relay B.
------	---------------------	---------------------------------------

4-7 Relay C Function
Option: **Function:**

		Selects the function of relay C (normally open).
	Off	Relay C is not used
	Main Contactor	The relay closes when the soft starter receives a start command, and remains closed as long as the motor is receiving voltage.
	Run	The relay closes when the soft starter changes to run state.
	Trip*	The relay closes when the starter trips.
	Warning	The relay closes when the soft starter issues a warning.
	Low Current Flag	The relay closes when the low current flag activates (<i>parameter 4-10 Low Current Flag</i>).
	High Current Flag	The relay closes when the high current flag activates (<i>parameter 4-11 High Current Flag</i>).

4-7 Relay C Function

Option: **Function:**

Motor Temp Flag	The relay closes when the motor temperature flag activates (<i>parameter 4-12 Motor Temperature Flag</i>).
-----------------	--

4-8 Relay C On Delay

Range: **Function:**

0 s*	[0:00–5:00 (min:s)]	Sets the delay for closing relay C.
------	---------------------	-------------------------------------

4-9 Relay C Off Delay

Range: **Function:**

0 s*	[0:00–5:00 (min:s)]	Sets the delay for reopening relay C.
------	---------------------	---------------------------------------

8.4.3 Low Current Flag and High Current Flag

The soft starter has low and high current flags to give early warning of abnormal operation. The current flags can be configured to indicate an abnormal current level during operation, between the normal operating level and the undercurrent or instantaneous overcurrent trip levels. The flags can signal the situation to external equipment via 1 of the programmable outputs. The flags clear when the current returns within the normal operating range by 10% of the programmed flag value.

4-10 Low Current Flag

Range: **Function:**

50%*	[1–100% FLC]	Sets the level at which the low current flag operates, as a percentage of motor full load current.
------	--------------	--

4-11 High Current Flag

Range: **Function:**

100%*	[50–600% FLC]	Sets the level at which the high current flag operates, as a percentage of motor full load current.
-------	---------------	---

8.4.4 Motor Temperature Flag

The soft starter has a motor temperature flag to give early warning of abnormal operation. The flag can indicate that the motor is operating above its normal operating temperature, but lower than the overload limit. The flag can signal the situation to external equipment via 1 of the programmable outputs.

4-12 Motor Temperature Flag

Range: **Function:**

80%*	[0–160%]	Sets the level at which the motor temperature flag operates, as a percentage of the motor thermal capacity.
------	----------	---

8.4.5 Analog Output A

The soft starter has an analog output, which can be connected to associated equipment to monitor motor performance.

4-13 Analog Output A

Option: **Function:**

	Selects which information is reported via analog output A.
Current (% FLC)*	Current as a percentage of motor full load current.
Motor Temp (%)	Motor temperature as a percentage of the thermal capacity of the motor.
Motor kW (%)	Measured motor kilowatts, as a percentage of maximum kW.
Motor kVA (%)	Measured motor kilovolt amperes, as a percentage of maximum kVA.
Motor pf	Motor power factor, measured by the soft starter. <ul style="list-style-type: none"> • Measure motor kW: $\sqrt{3} \times \text{average current} \times \text{mains reference voltage} \times \text{measure power factor}$. • Maximum motor kW: $\sqrt{3} \times \text{motor FLC} \times \text{mains reference voltage}$. Power factor is assumed to be 1. • Measure motor kVA: $\sqrt{3} \times \text{average current} \times \text{main reference voltage}$. • Maximum motor kVA: $\sqrt{3} \times \text{motor FLC} \times \text{mains reference voltage}$.

4-14 Analog A Scale

Option: **Function:**

	Selects the range of the output.
0–20 mA	
4–20 mA*	

4-15 Analog A Maximum Adjustment

Range: **Function:**

100%*	[0–600%]	Calibrates the upper limit of the analog output to match the signal measured on an external current measuring device.
-------	----------	---

4-16 Analog A Minimum Adjustment

Range: **Function:**

0%*	[0–600%]	Calibrates the lower limit of the analog output to match the signal measured on an external current measuring device.
-----	----------	---

8.5 Start/Stop Timers

CAUTION

UNINTENDED START

The auto-start timer overrides any other form of control. The motor may start without warning.

5-1 Auto-Start Type

Option: Function:

	Selects whether the soft starter auto-starts after a specified delay, or at a time of day.
Off*	The soft starter does not auto-start.
Timer	The soft starter does auto-start after a delay from the next stop, as specified in <i>parameter 5-2 Auto-start Time</i> .
Clock	The soft starter auto-starts at the time programmed in <i>parameter 5-2 Auto-start Time</i> .

5-2 Auto-Start Time

Range: Function:

1 min*	[00:01–24:00 (hrs:min)]	Sets the time for the soft starter to auto-start, in 24-hour clock format.
--------	-------------------------	--

5-3 Auto-Stop Type

Option: Function:

	Selects whether the soft starter auto-stops after a specified delay, or at a time of day.
Off*	The soft starter does not auto-stop.
Time	The soft starter auto-stops after a delay from the next start, as specified in <i>parameter 5-4 Auto-stop Time</i> .
Clock	The soft starter auto-stops at the time programmed in <i>parameter 5-4 Auto-stop Time</i> .

5-4 Auto-Stop Time

Range: Function:

1 min*	[00:01–24:00 (hrs:min)]	<p>Sets the time for the soft starter to auto-stop, in 24-hour clock format.</p> <p>⚠ WARNING</p> <p>Do not use this function with remote 2-wire control. The soft starter still accepts start and stop commands from the remote inputs or serial communication network. To disable local or remote control, use <i>parameter 3-1 Local/Remote</i>. If auto-start is enabled and the user is in the menu system, auto-start becomes active if the menu times out (if no LCP activity is detected for 5 minutes).</p>
--------	-------------------------	---

8.6 Auto-Reset

The soft starter can be programmed to reset certain trips automatically, which can help minimise operating downtime. Trips are divided into 3 categories for auto-reset, depending on the risk to the soft starter:

Group	
A	Current imbalance
	Phase loss
	Power loss
	Frequency
B	Undercurrent
	Instantaneous overcurrent
	Input A trip
C	Motor overload
	Motor thermistor
	Heat overtemperature

Table 8.1 Trip Categories for Auto-reset

Other trips cannot be automatically reset.

This function is ideal for remote installations using 2-wire control in *Auto On* mode. If the 2-wire start signal is present after an auto-reset, the soft starter restarts.

6-1 Auto-Reset Action

Option: Function:

	Selects which trips can be auto-reset.
Do not Auto-Reset*	
Reset Group A	
Reset Group A & B	
Reset Group A, B & C	

6-2 Maximum Resets

Range: Function:

1*	[1–5]	Sets how many times the soft starter auto-resets, if it continues to trip. The reset counter increases by 1 each time the soft starter auto-resets, and decreases by 1 after each successful start/stop cycle.
----	-------	--

NOTICE

If the starter is manually reset, the reset counter returns to 0.

8.6.1 Auto-Reset Delay

The soft starter can be configured to wait before auto-resetting a trip. Separate delays can be set for trips in Groups A and B, or in Group C.

6-3 Reset Delay Groups A & B

Range: Function:

5 s*	[00:05–15:00 (min:s)]	Sets the delay before setting Group A and Group B trips.
------	-----------------------	--

6-4 Reset Delay Group C

Range: Function:

5 min*	[5–60 (minutes)]	Sets the delay before resetting Group C trips.
--------	------------------	--

8.7 Secondary Motor Set

See *parameters 1-1 to 1-16* for details.

7-1 Motor FLC-2

Range: **Function:**

[Motor dependent]	Sets the secondary motor full load current.
-------------------	---

7-2 Locked Rotor Time-2

Range: **Function:**

10 s*	[0:01–2:00 (min:s)]	Sets the maximum length of the time the motor can run at locked rotor current from cold before reaching its maximum temperature. Set according to the motor datasheet. If this information is not available, set the value to <20 s.
-------	---------------------	---

7-3 Start Mode-2

Option: **Function:**

	Selects the soft start mode.
Constant Current*	
Adaptive Control	

7-4 Current Limit-2

Range: **Function:**

350%*	[100–600% FLC]	Sets the current limit for constant current and current ramp soft starting, as a percentage of motor full load current.
-------	----------------	---

7-5 Initial Current-2

Range: **Function:**

350%*	[100–600% FLC]	Sets the initial start current level for current ramp starting, as a percentage of motor full load current. Set so that the motor begins to accelerate immediately after a start is initiated. If current ramp starting is not required, set the initial current equal to the current limit.
-------	----------------	--

7-6 Start Ramp Time-2

Range: **Function:**

10 s*	[1–180 s]	Sets the total start time for an adaptive control start or the ramp time for current ramp starting (from the initial current to the current limit).).
-------	-----------	--

7-7 Kick Start Level-2

Range: **Function:**

500%*	[100–700% FLC]	Sets the level of the kick start current.
-------	----------------	---

7-8 Kick Start Time-2

Range: **Function:**

0000 ms*	[0–2000 ms]	Sets the kick start duration. A setting of 0 disables kick start.
----------	-------------	---

7-9 Excess Start Time-2

Range: **Function:**

	Excess start time is the maximum time the soft starter attempts to start the motor. If the motor does not reach full speed within the
--	---

7-9 Excess Start Time-2

Range: **Function:**

		programmed limit, the soft starter trips. Set for a period slightly longer than required for a normal healthy start. A setting of 0 disables excess start time protection.
20 s*	[0:00–4:00 (min:s)]	Set as required.

7-10 Stop Mode-2

Option: **Function:**

	Selects the stop mode.
Coast to Stop*	
TVR Soft Stop	
Adaptive Control	
Brake	

7-11 Stop Time-2

Range: **Function:**

0 s*	[0:00–4:00 (min:s)]	Sets the stop time.
------	---------------------	---------------------

7-12 Adaptive Control Gain-2

Range: **Function:**

75%*	[1–200%]	Adjusts the performance of adaptive control. The setting affects both starting and stopping control NOTICE Leave the gain setting at the default level unless adaptive control performance is not satisfactory. If the motor accelerates or decelerates quickly at the end of a start or stop, increase the gain by setting by 5–10%. If the motor speed fluctuates during starting or stopping, decrease the gain setting slightly.
------	----------	---

7-13 Adaptive Start Profile-2

Option: **Function:**

	Selects which profile the soft starter uses for an adaptive control soft start.
Early Acceleration	
Constant Acceleration*	
Late Acceleration	

7-14 Adaptive Stop Profile-2

Option: **Function:**

	Selects which profile the soft starter uses for an adaptive control soft stop.
Early Deceleration	
Constant Deceleration*	
Late Deceleration	

7-15 Brake Torque-2

Range:	Function:
20%* [20–100%]	Sets the amount of brake torque the soft starter uses to slow the motor.

7-16 Brake Time-2

Range:	Function:
1 s* [1–30 s]	<p>NOTICE This parameter is used with <i>parameter 7-11 Stop Time-2</i>.</p> <p>Sets the duration for DC injection during a braking stop.</p>

8.8 Display

8-1 Language

Option:	Function:
	Selects in which language the LCP displays messages and feedback.
English*	
Chinese (中文)	
Spanish (Español)	
German (Deutsch)	
Portuguese (Português)	
French (Français)	
Italian (Italiano)	
Russian (Русский)	

8.8.1 User Programmable Screen

Selects which 4 items to display on the programmable monitoring screen.

8-2 User Screen - Top Left

Option:	Function:
	Selects the item displayed in the top left part of the screen.
Blank	Displays no data in the selected area, allowing long messages to be shown without overlapping.
Starter State	The operating state of the soft starter (starting, running, stopping, or tripped). Only available for <i>Top L</i> and <i>Btm L</i> .
Motor Current	The average current measured on 3 phases.
Motor pf*	The motor power factor, measured by the soft starter.
Mains Frequency	The average frequency measured on 3 phases.
Motor kW	The motor running power in kilowatts.
Motor hp	The motor running power in horse power.
Motor Temp	The motor temperature, calculated by the thermal model.
kWh	The number of kilowatt hours the motor has run via the soft starter.

8-2 User Screen - Top Left

Option:	Function:
Hours Run	The number of hours the motor has run via the soft starter.

8-3 User Screen - Top Right

Option:	Function:
	Selects the item displayed in the top right part of the screen.
Blank*	Displays no data in the selected area, allowing long messages to be shown without overlapping.
Starter State	The operating state of the soft starter (starting, running, stopping, or tripped). Only available for <i>Top L</i> and <i>Btm L</i> .
Motor Current	The average current measured on 3 phases.
Motor pf	The motor power factor, measured by the soft starter.
Mains Frequency	The average frequency measured on 3 phases.
Motor kW	The motor running power in kilowatts.
Motor hp	The motor running power in horse power.
Motor Temp	The motor temperature, calculated by the thermal model.
kWh	The number of kilowatt hours the motor has run via the soft starter.
Hours Run	The number of hours the motor has run via the soft starter.

8-4 User Screen - Bottom Left

Option:	Function:
	Selects the item displayed in the bottom left part of the screen.
Blank	Displays no data in the selected area, allowing long messages to be shown without overlapping.
Starter State	The operating state of the soft starter (starting, running, stopping, or tripped). Only available for <i>Top L</i> and <i>Btm L</i> .
Motor Current	The average current measured on 3 phases.
Motor pf	The motor power factor, measured by the soft starter.
Mains Frequency	The average frequency measured on 3 phases.
Motor kW	The motor running power in kilowatts.
Motor hp	The motor running power in horse power.
Motor Temp	The motor temperature, calculated by the thermal model.
kWh	The number of kilowatt hours the motor has run via the soft starter.
Hours Run*	The number of hours the motor has run via the soft starter.

8-5 User Screen - Bottom Right
Option: Function:

	Selects the item displayed in the bottom right part of the screen.
Blank*	Displays no data in the selected area, allowing long messages to be shown without overlapping.
Starter State	The operating state of the soft starter (starting, running, stopping, or tripped). Only available for <i>Top L</i> and <i>Btm L</i> .
Motor Current	The average current measured on 3 phases.
Motor pf	The motor power factor, measured by the soft starter.
Mains Frequency	The average frequency measured on 3 phases.
Motor kW	The motor running power in kilowatts.
Motor hp	The motor running power in horse power.
Motor Temp	The motor temperature, calculated by the thermal model.
kWh	The number of kilowatt hours the motor has run via the soft starter.
Hours Run	The number of hours the motor has run via the soft starter.

8.8.2 Performance Graphs

The loggings menu allows to view performance information in real-time graphs.

The newest information is displayed at the right-hand edge of the screen. The graph can be paused to analyse data by pressing and holding [OK]. To restart the graph, press and hold [OK].

8-6 Graph Timebase
Option: Function:

	Sets the graph time scale. The graph progressively replaces the old data with new data.
10 s*	
30 s	
1 min	
5 minutes	
10 minutes	
30 minutes	
1 hour	

8-7 Graph Maximum Adjustment
Range: Function:

400%*	[0–600%]	Adjusts the upper limit of the performance graph
-------	----------	--

8-8 Graph Minimum Adjustment
Range: Function:

0%*	[0–600%]	Adjusts the lower limit of the performance graph.
-----	----------	---

8-9 Mains Reference Voltage
Range: Function:

400 V*	[100–690 V]	Sets the nominal voltage for the monitoring functions of the LCP. The nominal voltage is used to calculate motor kilowatts and kilovolt amperes (kVA), but does not affect the motor control protection of the soft starter. Enter the measured mains voltage.
--------	-------------	--

8.9 Restricted Parameters
15-1 Access Code
Range: Function:

0000*	[0000–9999]	Sets the access code to enter the simulation tools and counter resets or the restricted section of the programming menu (parameter group <i>15 Restricted Parameters</i> and higher). Press [Back] and [OK] to select which digit to alter, and use [▲] and [▼] to change the value. NOTICE If the access code is lost, contact the local Danfoss supplier for master access code that allows to reprogramme a new access code.
-------	-------------	--

15-2 Adjustment Lock
Option: Function:

	Selects whether the LCP allows parameters to be changed via the programming menu.
Read & Write*	Allows users to alter parameter values in the programming menu.
Read Only	Prevents users altering parameter values in the programming menu. Parameter values can still be viewed.
No Access	Prevents users adjusting parameters in the programming menu unless an access code is entered.
	NOTICE Changes to the adjustment lock setting take effect only after the programming menu has been closed.

15-3 Emergency Run

Option: Function:

			<p>CAUTION</p> <p>EQUIPMENT DAMAGE</p> <p>Continued use of emergency run is not recommended. Emergency run may compromise the soft starter life as all protections and trips are disabled.</p> <p>Using the soft starter in <i>Emergency run</i>-mode voids the product warranty.</p> <p>Selects whether the soft starter permits emergency run operation. In <i>Emergency run</i>, the soft starter starts (if not already running) and continues to operate until emergency run ends, ignoring stop commands and trips.</p> <p>Emergency run is controlled using a programmable input.</p> <p>When emergency run is activated in internally bypassed models which are not running, the soft starter attempts a normal start while ignoring all trips. If a normal start is not possible, a DOL start via the internal bypass contactors is attempted. For non-bypassed models, an external emergency run bypass contactor may be used.</p>
--	--	--	--

15-4 Current Calibration

Range: Function:

100%*	[85% - 115%]		<p>Motor Current Calibration calibrates the soft starter's current monitoring circuits to match an external current metering device.</p> <p>Use the following formula to determine the necessary adjustment:</p> $\text{Calibration (\%)} = \frac{\text{Current shown on MCD 500 display}}{\text{Current measured by external device}}$ <p>e.g. 102% = $\frac{66\text{ A}}{65\text{ A}}$</p> <p>NOTICE</p> <p>This adjustment affects all current-based functions.</p>
-------	--------------	--	--

15-5 Main Contactor Time

Range: Function:

400 ms*	[100– 2000 ms]		<p>Sets the delay period between the soft starter switching the main contactor output (terminals 13, 14) and beginning the pre-start checks (before start) or entering the not ready state (after a stop). Set according to the specifications of the main contactor used.</p>
---------	----------------	--	--

15-6 Bypass Contactor Time

Range: Function:

150 ms*	[100– 2000 ms]		<p>Sets the soft starter to match the bypass contactor closing/opening time. Set according to the specifications of the bypass contactor used. If the time is too short, the soft starter trips.</p>
---------	----------------	--	--

15-7 Motor Connection

Option: Function:

			<p>Selects the soft starter automatically detects the format of the connection to the motor.</p>
	Auto-Detect*		
	In-line		
	Inside Delta		

15-8 Jog Torque

Range: Function:

50%*	[20–100%]		<p>NOTICE</p> <p>Setting this parameter above 50% may cause increased shaft vibration.</p> <p>Sets the torque level for jog operation. See chapter 5.5 <i>Jog Operation</i> for more details.</p>
------	-----------	--	--

8.10 Protection Action

16-1 to 16-13 Protection Action

Option: Function:

			<p>Selects the soft starter response to each protection.</p> <ul style="list-style-type: none"> • 16-1 Motor Overload. • 16-2 Current Imbalance. • 16-3 Undercurrent. • 16-4 Inst Overcurrent. • 16-5 Frequency. • 16-6 Heat sink Overtemp. • 16-7 Excess Start Time. • 16-8 Input A Trip. • 16-9 Motor Thermistor. • 16-10 Starter/Comms. • 16-11 Network/Comms. • 16-12 Battery/Clock. • 16-13 Low Control Volts.
	Trip Starter*		
	Warn and Log		
	Log Only		

8.11 Factory Parameters

These parameters are restricted for factory use and are not available to the user.

9 Tools

To access *Tools*:

1. Open the Main Menu.
2. Scroll to *Tools*.
3. Press [OK].

NOTICE

The security access code also protects simulation tools and counter resets. The default access code is 0000.

9.1 Set Date and Time

To set the date and time:

1. Open the Tools Menu.
2. Scroll to *Set Date & Time*.
3. Press [OK] to enter edit mode.
4. Press [OK] to select which part of the date or time to edit.
5. Use [▲] and [▼] to change the value.

To save changes, press [OK] repeatedly. The soft starter confirms the changes. To cancel changes, press [Back] repeatedly.

9.2 Load/Save Settings

The MCD 500 includes options to:

- Load defaults: Load the soft starter parameters with default values.
- Load User Set 1: Reload previously saved parameter settings from an internal file.
- Save User Set 1: Save the current parameter settings to an internal file.

In addition to the factory default values file, the soft starter can store a user-defined parameter file. This file contains default values until a user file is saved.

To load or save parameter settings:

1. Open the Tools Menu.
2. Use [▼] to select the required function, then press [OK].
3. At the confirmation prompt, select *Yes* to confirm or *No* to cancel. Then press [OK] to load/save the selection or exit the screen.

Tools	Load Defaults
	Load User Set 1
	Save User Set 1

Table 9.1 Tools Menu

Load Defaults
No
Yes

Table 9.2 Load Defaults Menu

When the action has been completed, the screen briefly displays a confirmation message, then returns to the status screens.

9.3 Reset Thermal Model

NOTICE

The security access code protects the reset thermal model.

The advanced thermal modelling software in the soft starter constantly monitors the motor performance. This monitoring allows the soft starter to calculate the motor temperature and ability to start successfully at any time.

If necessary, reset the thermal model.

CAUTION

Resetting the motor thermal model may compromise motor life and should only be done in the case of emergency.

1. Open *Tools*.
2. Scroll to *Reset Thermal Model* and press [OK].
3. At the confirmation prompt, press [OK] to confirm then enter the access code, or press [Back] to cancel the action.
4. Select *Reset* or *Do Not Reset*, then press [OK]. When the thermal model has been reset, the soft starter returns to the previous screen.

Reset Thermal Model
M1 X%
OK to Reset

Table 9.3 Accept to Reset the Thermal Model

Reset Thermal Model Do Not Reset Reset
--

Table 9.4 Reset Thermal Model Menu

9.4 Protection Simulation

NOTICE

The security access code protects protection simulation.

To test the operation and control circuits of the soft starter without connecting it to mains voltage, use the software simulation functions.

To confirm that the soft starter responds correctly and reports the situation on the display and across the communication network, it is able to simulate each different protection.

To use the protection simulation:

1. Open the Main Menu.
2. Scroll to *Protection Sim* and press [OK].
3. To select the protection to simulate, press [▲] and [▼].
4. To simulate the selected protection, press [OK].
5. The screen is displayed while [OK] is pressed. The soft starter response depends on the protection action setting (parameter group *16 Protection Actions*).
6. To return to the simulation list, press [Back].
7. To select another simulation, press [▲] or [▼], or press [Back] to return to the Main Menu.

MS1	000.0A	0000.0kW
Tripped		
Selected Protection		

Table 9.5 Protection Simulation Menu

NOTICE

If the protection trips the soft starter, reset before simulating another protection. If the protection action is set to *Warn or Log*, no reset is required.

If the protection is set to *Warn & Log*, the warning message can be viewed only while [OK] is pressed.

If the protection is set to *Log only*, nothing appears on the screen but an entry appears in the log.

9.5 Output Signal Simulation

NOTICE

The security access code protects the output signal simulation.

The LCP allows simulation of output signalling to confirm that the output relays are operating correctly.

NOTICE

To test operation of the flags (motor temperature and low/high current), set an output relay to the appropriate function and monitor the relay behaviour.

To use the output signal simulation:

1. Open the Main Menu.
2. Scroll to *Output Signal Sim* and press [OK], then enter the access code.
3. To select a simulation, press [▲] and [▼], then press [OK].
4. To turn the signal on and off, press [▲] and [▼]. To confirm correct operation, monitor the state of the output.
5. To return to the simulation list, press [Back].

Prog Relay A
Off
On

Table 9.6 Output Signal Simulation Menu

9.6 Digital I/O State

This screen shows the status of the Digital I/O in order.

The top line of the screen shows:

- Start.
- Stop.
- Reset.
- Programmable input.

The bottom line of the screen shows programmable outputs A, B, and C.

Digital I/O State
Inputs: 0100
Outputs: 100

Table 9.7 Digital I/O Status Screen

9.7 Temp Sensors State

This screen shows the state of the motor thermistor. The screen shot shows the thermistor state as O (open).

Temp Sensors State
Thermistor: O
S = shrt H=hot C=cld O=opn

Table 9.8 Motor Thermistor Status Screen

9.8 Alarm Log

The [Alarm Log] key opens the alarm logs, which contain:

- Trip log.
- Event log.
- Counters which store information on the soft starter operating history.

9.8.1 Trip Log

The trip log stores details of the 8 most recent trips, including the date and time the trip happened. Trip 1 is the most recent and trip 8 is the oldest stored trip.

To open the trip log

1. Press [Alarm Log].
2. Scroll to *Trip Log* and press [OK].
3. To select a trip to view, press [▲] and [▼], then press [OK] to display details.

To close the log and return to the main display, press [Back].

9.8.2 Event Log

The event log stores time-stamped details of the 99 most recent events (actions, warnings, and trips), including the date and time of the event. Event 1 is the most recent and event 99 is the oldest stored event.

To open the event log:

1. Press [Alarm Log].
2. Scroll to *Event Log* and press [OK].
3. To select an event to view, press [▲] and [▼], then press [OK] to display details.

To close the log and return to the main display, press [Back].

9.8.3 Counters

NOTICE

The security access code protects the counters function.

The performance counters store statistics on the soft starter operation:

- Hours run (lifetime and since counter last reset).
- Number of starts (lifetime and since counter last reset).
- Motor kWh (lifetime and since counter last reset).
- Number of times the thermal model has been reset.

The resettable counters (hours run, starts, and motor kWh) can only be reset if the correct access code is entered.

To view the counters:

1. Press [Alarm Log].
2. Scroll to *Counters* and press [OK].
3. To scroll through the counters, press [▲] and [▼]. Press [OK] to view details.
4. To reset a counter, press [OK] then enter the access code. Select Reset, then press [OK] to confirm.

To close the counter and return to the alarm logs, press [Back].

10 Troubleshooting

When a protection condition is detected, the MCD 500 writes this condition to the event log, and may also trip, or issue a warning. The soft starter response depends on the protection action settings (parameter group 16 *Protection Actions*).

Some protections responses cannot be adjusted. Usually, external events (for example phase loss) or a fault within the soft starter cause these trips. These trips do not have associated parameters and cannot be set to *Warn* or *Log*.

If the soft starter trips:

1. Identify and clear the condition that triggered the trip.
2. Reset the soft starter.
3. Restart the soft starter.

To reset the soft starter, press [Reset] or activate the *Reset remote* input.

If the soft starter has issued a warning, it resets itself once the cause of the warning has been resolved.

10.1 Trip Messages

Table 10.1 lists the protection mechanisms in the soft starter and the probable cause of the trip. Some of these protection mechanisms can be adjusted using parameter group 2 *Protection* and parameter group 16 *Protection Action*. Other settings are built-in system protections and cannot be set or adjusted.

Display	Possible cause/Suggested solution
Awaiting data	The LCP does not receive data from the control PCB. Check the cable connection and the fitting of the display on the soft starter.
Battery/clock	A verification error has occurred on the real-time clock, or the back-up battery voltage is low. If the battery is low and the power is off, date/time settings are lost. Reprogramme the date and time. Related parameter: <ul style="list-style-type: none"> • <i>Parameter 16-12 Battery Clock.</i>
Controller	This is a name selected for a programmable input. Refer to <i>Input A trip</i> .
Current imbalance	Problems with the motor, the environment, or the installation can cause current imbalance, such as: <ul style="list-style-type: none"> • An imbalance in the incoming mains voltage. • A problem with the motor windings. • A light load on the motor. • A phase loss on mains terminals L1, L2, or L3 during run mode. An SCR that has failed open circuit. A failed SCR can only be definitely diagnosed by replacing the SCR and checking the soft starter performance. Related parameters: <ul style="list-style-type: none"> • <i>Parameter 2-2 Current Imbalance.</i> • <i>Parameter 2-3 Current Imbalance Delay.</i> • <i>Parameter 16-2 Current Imbalance.</i>
Current read err lx	Where X is 1, 2, or 3. Internal fault (PCB fault). The output from the current transformer circuit is not close enough to zero when the SCRs are turned off. Contact the local Danfoss supplier for advice. This trip is not adjustable. Related parameters: None.

Display	Possible cause/Suggested solution
Excess start time	<p>Excess start time trip can occur in the following conditions:</p> <ul style="list-style-type: none"> • <i>Parameter 1-1 Motor Full Load Current</i> is not appropriate for the motor. • <i>Parameter 1-4 Current Limit</i> has been set too low. • <i>Parameter 1-6 Start Ramp Time</i> has been set greater than the setting for <i>Parameter 1-9 Excess Start Time Setting</i>. • <i>Parameter 1-6 Start Ramp Time</i> is set too short for a high inertia load when using adaptive control. <p>Related parameters:</p> <ul style="list-style-type: none"> • <i>Parameter 1-1 Motor FLC</i>. • <i>Parameter 1-6 Start Ramp Time</i>. • <i>Parameter 1-4 Current Limit</i>. • <i>Parameter 1-9 Excess Start Time</i>. • <i>Parameter 7-9 Excess Strt Time-2</i>. • <i>Parameter 7-1 Motor FLC-2</i>. • <i>Parameter 7-6 Start Ramp-2</i>. • <i>Parameter 7-4 Current Limit-2</i>. • <i>Parameter 16-7 Excess Start Time</i>.
Firing fail px	<p>Where X is phase 1, 2, or 3.</p> <p>The SCR did not fire as expected. Check for faulty SCRs and internal wiring faults.</p> <p>This trip is not adjustable.</p> <p>Related parameters: None.</p>
FLC too high	<p>The soft starter can support higher motor FLC full load current values when connected to the motor using inside delta configuration rather than in-line connection. If the soft starter is connected in-line, but the programmed setting for <i>parameter 1-1 Motor Full Load Current</i> exceeds the in-line maximum, the soft starter trips at start (see <i>chapter 4.5 Minimum and Maximum Current Settings</i>).</p> <p>If the soft starter is connected to the motor using inside delta configuration, check that the soft starter detects the connection correctly. Contact the local Danfoss supplier for advice.</p> <p>Related parameters:</p> <ul style="list-style-type: none"> • <i>Parameter 1-1 Motor FLC</i>. • <i>Parameter 7-1 Motor FLC-2</i>.
Frequency	<p>The mains frequency has gone beyond the specified range.</p> <p>Check for other equipment in the area that could be affecting the mains supply, particularly frequency converters, and switch mode power supplies (SMPS).</p> <p>If the soft starter is connected to a generator-set supply, the generator may be too small or could have a speed control problem.</p> <p>Related parameters:</p> <ul style="list-style-type: none"> • <i>Parameter 2-8 Frequency Check</i>. • <i>Parameter 2-9 Frequency Variation</i>. • <i>Parameter 2-10 Frequency Delay</i>. • <i>Parameter 16-5 Frequency</i>.

Display	Possible cause/Suggested solution
Heat sink overtemp	<p>Check that cooling fans are operating. If mounted in an enclosure, check if ventilation is adequate. Fans operate during start, run, and for 10 minutes after the soft starter exits the stop state.</p> <p>NOTICE</p> <p>Models MCD5-0021B ~ MCD4-0053B and MCD5-0141B do not have a cooling fan. Models with fans operate the cooling fans from a start until 10 minutes after a stop.</p> <p>Related parameters:</p> <ul style="list-style-type: none"> • <i>Parameter 16-6 Heat sink Overtemp.</i>
High level	This is a name selected for a programmable input. Refer to <i>Input A trip</i> .
High pressure	This is a name selected for a programmable input. Refer to <i>Input A trip</i> .
Input A trip	<p>The programmable input is set to a trip function and has activated. Resolve the trigger condition.</p> <p>Related parameters:</p> <ul style="list-style-type: none"> • <i>Parameter 3-3 Input A Function.</i> • <i>Parameter 3-4 Input A Name.</i> • <i>Parameter 3-5 Input A Trip.</i> • <i>Parameter 3-6 Input A Trip Delay.</i> • <i>Parameter 3-7 Input A Initial Delay.</i> • <i>Parameter 16-8 Input A Trip.</i>
Instantaneous overcurrent	<p>There has been a sharp rise in motor current, probably caused by a locked rotor condition (shear pin) while running. Check for a jammed load.</p> <p>Related parameters:</p> <ul style="list-style-type: none"> • <i>Parameter 2-6 Instantaneous Overcurrent.</i> • <i>Parameter 2-7 Instantaneous Overcurrent Delay.</i> • <i>Parameter 16-4 Inst Overcurrent.</i>
Internal fault X	<p>The soft starter has tripped on an internal fault. Contact the local Danfoss supplier with the fault code (X).</p> <p>Related parameters: None.</p>
L1 phase loss L2 phase loss L3 phase loss	<p>During prestart, check that the soft starter has detected a phase loss as indicated.</p> <p>In run state, the soft starter has detected that the current on the affected phase has dropped below 3.3% of the programmed motor FLC for more than 1 s. This current drop indicates that either the incoming phase or connection to the motor has been lost.</p> <p>Check the supply and the input, and output connections at the soft starter, and at the motor end. A failed SCR can also cause phase loss, particularly an SCR that has failed open circuit. A failed SCR can only be definitely diagnosed by replacing the SCR and checking the soft starter performance.</p> <p>Related parameters: None.</p>
L1-T1 shorted L2-T2 shorted L3-T3 shorted	<p>During prestart checks, the soft starter has detected a shorted SCR or a short within the bypass contactor as indicated.</p> <p>Related parameters: None.</p>
Low control volts	<p>The soft starter has detected a drop in the control voltage.</p> <ul style="list-style-type: none"> • Check the external control supply (terminals A4, A5, A6) and reset the soft starter. <p>If the external control supply is stable:</p> <ul style="list-style-type: none"> • Check if the 24 V supply on the main control PCB is faulty; or • If the bypass driver PCB is faulty (internally bypassed models only). <p>This protection is not active in ready state.</p> <p>Related parameters:</p> <ul style="list-style-type: none"> • <i>Parameter 16-13 Low Control Volts.</i>
Low level	This is a name selected for a programmable input. Refer to <i>Input A trip</i> .
Low pressure	This is a name selected for a programmable input. Refer to <i>Input A trip</i> .

Display	Possible cause/Suggested solution
Motor overload/ Motor 2 overload	<p>The motor has reached its maximum thermal capacity. The following can cause overload:</p> <ul style="list-style-type: none"> • The soft starter protection settings not matching the motor thermal capacity. • Excessive starts per hour. • Excessive throughput. • Damage to the motor windings. <p>Resolve the cause of the overload and allow the motor to cool.</p> <p>Related parameters:</p> <ul style="list-style-type: none"> • <i>Parameter 1-1 Motor Full Load Current.</i> • <i>Parameter 1-2 Locked Rotor Time.</i> • <i>Parameter 1-3 Start Mode.</i> • <i>Parameter 1-4 Current Limit.</i> • <i>Parameter 7-1 Motor FLC-2.</i> • <i>Parameter 7-2 Locked Rotor Time-2.</i> • <i>Parameter 7-3 Start Mode-2.</i> • <i>Parameter 7-4 Current Limit-2.</i> • <i>Parameter 16-1 Motor Overload.</i>
Motor connection tx	<p>Where X is 1, 2, or 3.</p> <p>The motor is not connected correctly to the soft starter for inline or inside delta use.</p> <ul style="list-style-type: none"> • Check individual motor connections to the soft starter for power circuit continuity. • Check connections at the motor terminal box. <p>This trip is not adjustable.</p> <p>Related parameters:</p> <ul style="list-style-type: none"> • <i>Parameter 15-7 Motor Connection.</i>
Motor thermistor	<p>The motor thermistor input has been enabled and:</p> <ul style="list-style-type: none"> • The resistance at the thermistor input has exceeded 3.6 kΩ for more than 1 s. • The motor winding has overheated. Identify the cause of the overheating and allow the motor to cool before restarting. • The motor thermistor input has been open. <p>NOTICE If a valid motor thermistor is no longer used, fit a 1.2 kΩ resistor across terminals 05, 06.</p> <p>Related parameters:</p> <ul style="list-style-type: none"> • <i>Parameter 16-9 Motor Thermistor.</i>
Network communication (between module and network)	<p>The network master has sent a trip command to the soft starter, or there could be a network communication problem.</p> <p>Check the network for causes of communication inactivity.</p> <p>Related parameters:</p> <ul style="list-style-type: none"> • <i>Parameter 16-11 Network/Comms.</i>
No flow	<p>This is a name selected for a programmable input. Refer to <i>Input A trip</i>.</p>
Not ready	<p>Check input A (terminals 11, 16). Check if the soft starter disable function is active. If <i>Parameter 3-3 Input A Function</i> is set to <i>Starter disable</i> and there is an open circuit on terminals 11, 16, the soft starter does not start.</p>

Display	Possible cause/Suggested solution
Overpower	The motor has experienced a sharp rise in power. Causes can include a momentary overload condition which has exceeded the adjustable delay time. Related parameters: <ul style="list-style-type: none"> • 2U. • 2V. • 16P.
Parameter out of range	<ul style="list-style-type: none"> • A parameter value is outside the valid range. The soft starter loads the default value for all affected parameters. To go to the first invalid parameter and adjust the setting, press [Main Menu]. Related parameters: None.
Phase sequence	The phase sequence on the soft starter mains terminals (L1, L2, L3) is not valid. Check the phase sequence on L1, L2, L3, and ensure that the setting in <i>parameter 2-1 Phase Sequence</i> is suitable for the installation. Related parameters: <i>Parameter 2-1 Phase Sequence</i> .
PLC	This is a name selected for a programmable input. Refer to <i>Input A trip</i> .
Power loss	The soft starter is not receiving mains supply on 1 or more phases when a start command is given. Check that the main contactor closes when a start command is given, and remains closed until the end of a soft stop. If testing the soft starter with a small motor, it must draw at least 2% of its minimum FLC setting on each phase. Related parameters: None.
Pump fault	This is a name selected for a programmable input. Refer to <i>Input A trip</i> .
Starter/communication (between module and soft starter)	<ul style="list-style-type: none"> • There is a problem with the connection between the soft starter and the optional communications module. Remove and reinstall the module. If the problem persists, contact the local distributor. • There is an internal communications error within the soft starter. Contact the local distributor. Related parameters: <ul style="list-style-type: none"> • <i>Parameter 16-10 Starter/Comms</i>.
Starter disable	This is a name selected for a programmable input. Refer to <i>Input A trip</i> .
Thermistor cct (thermistor circuit)	The thermistor input has been enabled and: <ul style="list-style-type: none"> • The resistance at the input has dropped below 20 Ω (the cold resistance of most thermistors is over this value) or • A short circuit has occurred. Check and resolve this condition. Check that a PT100 (RTD) is not connected to terminals 05, 06. Related parameters: None.
Time - overcurrent	The soft starter is internally bypassed and has drawn high current during running. (The 10 A protection curve trip has been reached or the motor current has risen to 600% of the motor FLC setting.) Related parameters: None.
Undercurrent	The motor has experienced a sharp drop in current, caused by loss of load. Causes can include broken components (shafts, belts, or couplings), or a pump running dry. Related parameters: <ul style="list-style-type: none"> • <i>Parameter 2-4 Undercurrent</i>. • <i>Parameter 2-5 Undercurrent Delay</i>. • <i>Parameter 16-3 Undercurrent</i>.
Unsupported option (function not available in inside delta)	The selected function is not available (for example jog is not supported in inside delta configuration). Related parameters: None.
Vibration alarm	This is a name selected for a programmable input. Refer to <i>Input A trip</i> .

Display	Possible cause/Suggested solution
VZC fail px	Where X is 1, 2, or 3. Internal fault (PCB fault). Contact the local Danfoss supplier for advice. This trip is not adjustable. Related parameters: None.

Table 10.1 Trip Messages

10.2 General Faults

Table 10.2 describes situations where the soft starter does not operate as expected but does not trip or issues a warning.

Symptom	Probable cause
Soft starter not ready.	Check input A (11, 16). Check if the soft starter is disabled via a programmable input. If <i>parameter 3-3 Input A Function</i> is set to <i>Starter disable</i> , and there is an open circuit on the corresponding input, the soft starter does not start.
The soft starter does not respond to the [Hand On] and [Reset] keys.	Check if the soft starter is in <i>Remote control</i> mode. When the soft starter is in <i>Remote control</i> mode, the <i>Hand on</i> LED on the soft starter is off. Press [Auto On] once to change to local control.
Soft starter does not respond to commands from the control inputs.	<ul style="list-style-type: none"> The soft starter waits for the restart delay to elapse. <i>Parameter 2-11 Restart delay</i> controls the length of the restart delay. The motor may be too hot to permit a start. If <i>parameter 2-12 Motor temperature check</i> is set to <i>Check</i>, the soft starter only permits a start when it calculates that the motor has sufficient thermal capacity to complete the start successfully. Wait for the motor to cool before attempting another start. Check if the soft starter is disabled via a programmable input. If <i>parameter 3-3 Input A Function</i> is set to <i>Starter disabled</i>, and there is an open circuit on terminals 11, 16, the soft starter does not start. If there is no further need to disable the soft starter, close the circuit on the input. <p>NOTICE <i>Parameter 3-1 Local/remote controls when the [Auto On] key is enabled.</i></p>
The soft starter does not respond to a start command from either the local or remote controls.	<ul style="list-style-type: none"> The soft starter may be waiting for the restart delay to elapse. <i>Parameter 2-11 Restart delay</i> controls the length of the restart delay. The motor may be too hot to permit a start. If <i>parameter 2-12 Motor temperature check</i> is set to <i>Check</i>, the soft starter only permits a start when it calculates that the motor has sufficient thermal capacity to complete the start successfully. Check if the soft starter is disabled via a programmable input. If <i>parameter 3-3 Input A function</i> is set to <i>Starter disable</i> and there is an open circuit on terminals 11, 16, the soft starter does not start. If there is not further need to disable the soft starter, close the circuit on the input. <p>NOTICE <i>Parameter 3-1 Local/remote controls when [Auto on] is enabled.</i></p>
The soft starter does not control the motor correctly during starting.	<ul style="list-style-type: none"> Start performance may be unstable when using a low motor FLC setting (<i>parameter 1-1 Motor Full Load Current</i>). This can affect use on a small test motor with full load current of 5–50 A. Install power factor correction (PFC) capacitors on the supply side of the soft starter. To control a dedicated PFC capacitor contactor, connect the contactor to run relay terminals.

Symptom	Probable cause
Motor does not reach full speed.	<ul style="list-style-type: none"> If the start current is too low, the motor does not produce enough torque to accelerate to full speed. The soft starter may trip on excess start time. <p>NOTICE Make sure that the motor starting parameters are appropriate for the application and that the intended motor starting profile is used. If parameter 3-3 Input A Function is set to Motor Set Select, check that the corresponding input is in the expected state.</p> <ul style="list-style-type: none"> Check if the load is jammed. Check the load for severe overloading or a locked rotor situation.
Erratic motor operation.	<ul style="list-style-type: none"> The SCRs in the soft starter require at least 5 A of current to latch. If testing the soft starter on a motor with full load current less than 5 A, the SCRs may not latch correctly.
Erratic and noisy motor operation.	<p>If the soft starter is connected to the motor using inside delta configuration, the soft starter may not be correctly detecting the connection. Contact the local Danfoss supplier for advice.</p>
Soft stop ends too quickly.	<ul style="list-style-type: none"> The soft stop settings may not be appropriate for the motor and load. Review the settings of <ul style="list-style-type: none"> Parameter 1-10 Stop Mode. Parameter 1-11 Stop Time. Parameter 7-10 Stop Mode-2. Parameter 7-11 Stop Time-2. If the motor is lightly loaded, soft stop has limited effect.
Adaptive control, DC brake, and jog functions not working.	<ul style="list-style-type: none"> These features are only available with in-line installation. If the soft starter is installed inside delta, these features do not operate.
A reset does not occur after an auto-reset, when using a remote 2-wire control.	<ul style="list-style-type: none"> Remove and reapply the remote 2-wire start signal for a restart.
Remote start/stop command overrides Auto Start/Stop settings when using remote 2-wire control.	<ul style="list-style-type: none"> Only use Auto Start/Stop in <i>Auto On</i> mode with 3-wire or 4-wire control.
After selecting adaptive control, the motor used an ordinary start and/or the second start was different to the first.	<ul style="list-style-type: none"> The first adaptive control start is current limit so that the soft starter can learn from the motor characteristics. Subsequent starts use adaptive control.
Non-resettable THERMISTOR CCT trip, when there is a link between thermistor input 05, 06 or when the motor thermistor connected between 05, 06 is permanently removed.	<ul style="list-style-type: none"> The thermistor input is enabled once a link is fitted and short-circuit protection has activated. <p>Remove the link then load the default parameter set. This disables the thermistor input and clears the trip. Place a 1k2 Ω resistor across the thermistor input. Turn thermistor protection to <i>Log only</i> (parameter 16-9 Motor Thermistor).</p>
Parameter settings cannot be stored.	<ul style="list-style-type: none"> Make sure to save the new value by pressing [OK] after adjusting a parameter setting. If pressing [BACK], the change is not saved. Check that the adjustment lock (parameter 15-2 Adjustment Lock) is set to <i>Read/Write</i>. If the adjustment lock is on, settings can be viewed, but not changed. Knowing the security access code is necessary to change the adjustment lock setting. The EEPROM may be faulty on the main control PCB. A faulty EEPROM also trips the soft starter, and the LCP displays the message <i>Par. Out of Range</i>. Contact the local Danfoss supplier for advice.
The LCP shows message <i>Awaiting data</i> .	<p>The LCP does not receive data from the control PCB. Check the cable connection.</p>

Table 10.2 General Fault Messages

11 Specifications

Supply

Mains voltage (L1, L2, L3)	
MCD5-xxxx-T5	200–525 V AC (±10%)
MCD5-xxxx-T7	380–690 V AC (±10%) (in-line connection)
MCD5-xxxx-T7	380–600 V AC (±10%) (inside delta connection)
Control voltage (A4, A5, A6)	
CV1 (A5, A6)	24 V AC/V DC (±20%)
CV2 (A5, A6)	110–120 V AC (+10%/-15%)
CV2 (A4, A6)	220–240 V AC (+10%/-15%)
Current consumption (maximum)	
CV1	2.8 A
CV2 (110–120 V AC)	1 A
CV2 (220–240 V AC)	500 mA
Mains frequency	45–66 Hz
Rated insulation voltage to ground	600 V AC
Rated impulse withstand voltage	4 kV
Form designation	Bypassed or continuous, semiconductor motor starter form 1

Short circuit capability (IEC)

Coordination with semiconductor fuses	Type 2
Coordination with HRC fuses	Type 1
MCD5-0021B to MCD5-0215B	prospective current 65 kA
MCD5-0245B to MCD5-0961B	prospective current 85 kA
MCD5-0245C to MCD5-0927B	prospective current 85 kA
MCD5-1200C to MCD5-1600C	prospective current 100 kA

For UL short circuit current ratings, see Table 4.12.

Electromagnetic capability (compliant with EU Directive 89/336/EEC)

EMC emissions	IEC 60947-4-2 Class B and Lloyds Marine No 1 Specification
EMC immunity	IEC 60947-4-2

Inputs

Input rating	Active 24 V DC, 8 mA approximately
Start (15, 16)	Normally open
Stop (17, 18)	Normally closed
Reset (25, 18)	Normally closed
Programmable input (11, 16)	Normally open
Motor thermistor (05, 06)	Trip >3.6 kΩ, reset <1.6kΩ

Outputs

Relay outputs	10 A @ 250 V AC resistive, 5A @ 250 V AC AC15 pf 0.3
Programmable outputs	
Relay A (13, 14)	Normally open
Relay B (21, 22, 24)	Change-over
Relay C (33, 34)	Normally open
Analog output (07, 08)	0–20 mA or 4–20 mA (selectable)
Maximum load	600 Ω (12 V DC @ 20 mA)
Accuracy	±5%
24 V DC output (16, 08) maximum load	200 mA
Accuracy	±10%

Environmental
Protection

MCD5-0021B to MCD5-0105B	IP20 & NEMA, UL Indoor Type 1
MCD5-0131B to MCD5-1600C	IP00, UL Indoor Open Type
Operating temperature	-10 °C to +60 °C, above 40 °C with derating
Storage temperature	-25 °C to +60 °C
Operating altitude (using MCD PC software)	0–1000 m, above 1000 m with derating
Humidity	5–95% relative humidity
Pollution degree	Pollution degree 3
Vibration	IEC 60068-2-6

Heat Dissipation

During start	4.5 W per ampere
During run	
MCD5-0021B to MCD5-0053B	≤39 W approximately
MCD5-0068B to MCD5-0105B	≤51 W approximately
MCD5-0131B to MCD5-0215B	≤120 W approximately
MCD5-0245B to MCD5-0469B	≤140 W approximately
MCD5-0525B to MCD5-0961B	≤357 W approximately
MCD5-0245C to MCD5-0927C	4.5 W per ampere approximately
MCD5-1200C to MCD5-1600C	4.5 W per ampere approximately

Certification

C✓	IEC 60947-4-2 UL 508 ¹⁾
UL/C-UL	UL-listed
MCD5-0021B to MCD5-0396B, MCD5-0245C to MCD5-1600C	UL-recognised
MCD5-0469B to MCD5-0961B	IP20 and NEMA 1, UL Indoor Type 1
MCD5-0021B to MCD5-105B	IP00, UL Indoor Open Type
MCD5-0131B to MCD5-1600C	IP20, when fitted with optional finger guard kit
CE	IEC 60947-4-2
CCC	GB 14048-6
Marine (MCD5-0021B to MCD5-0961B)	Lloyds Marine No 1 Specification
RoHS	Compliant with EU Directive 2002/95/EC

1) For UL certification extra requirements may apply, depending on the models. For details, see chapter 11.1 UL Compliant Installation.

11.1 UL Compliant Installation

This section details more requirements and configuration settings for the VLT® Soft Starter MCD 500 to be UL-compliant. See also *Table 4.12*.

11.1.1 Models MCD5-0021B to MCD5-0105B

There are no additional requirements for these models.

11.1.2 Models MCD5-0131B to MCD5-0215B

- Use with finger guard kit, ordering number 175G5662.
- Use the recommended pressure terminal/connector kit. See *Table 11.1* for more information.

11.1.3 Models MCD5-0245B to MCD5-0396B

- Use with finger guard kit, ordering number 175G5XXX.
- Use the recommended pressure terminal/connector kit. See *Table 11.1* for more information.

11.1.4 Models MCD5-0245C

- Use the recommended pressure terminal/connector kit. See *Table 11.1* for more information.

11.1.5 Models MCD5-0360C to MCD5-1600C

- Configure the busbars for line/load terminals at opposite ends of the soft starter (that is *Top in/Bottom out*, or *Top out/Bottom in*).
- Use the recommended pressure terminal/connector kit. See *Table 11.1* for more information.

11.1.6 Models MCD5-0469B to MCD5-0961B

These models are UL recognised components. Separate cable landing busbars may be required within the electrical cabinet when terminating cables sized according to the National Wiring Code (NEC) regulations.

11.1.7 Pressure Terminal/Connector Kits

For models MCD50131B to MCD5-0396B and MCD5-0245C to MCD5-1600C to be UL-compliant, use the recommended pressure terminal/connector as detailed in *Table 11.1*.

Model	FLC (A)	Number of wires	Recommended lugs ordering numbers
MCD5-0131B	145	1	OPHD 95-16
MCD5-0141B	170	1	OPHD 120-16
MCD5-0195B	200	1	OPHD 150-16
MCD5-0215B	220	1	OPHD 185-16
MCD5-0245B	255	1	OPHD 240-20
MCD5-0331B	350	1	OPHD 400-16
MCD5-0396B	425	2	OPHD 185-16
MCD5-0245C	255	1	OPHD 240-20
MCD5-0360C	360	2	1 x 600T-2
MCD5-0380C	380		
MCD5-0428C	430		
MCD5-0595C	620		
MCD5-0619C	650		
MCD5-0790C	790	4	2 x 600T-2
MCD5-0927C	930	3	2 x 600T-2
MCD5-1200C	1200	4	1 x 750T-4
MCD5-1410C	1410		
MCD5-1600C	1600	5	1 x 750T-4 and 1 x 600T-3

Table 11.1 Pressure Terminal/Connector Kits

11.2 Accessories

11.2.1 LCP Remote Mounting Kit

The MCD 500 LCP can be mounted up to 3 metres away from the soft starter, allowing remote control and monitoring. The remote LCP also allows parameter settings to be copied between soft starters.

- 175G0096 Control Panel LCP 501

11.2.2 Communication Modules

MCD 500 soft starters support network communication via easy-to-install communication modules. Each soft starter can support 1 communication module at a time.

Available protocols:

- Ethernet (PROFINET, Modbus TCP, Ethernet/IP).
- PROFIBUS.
- DeviceNet.

- Modbus RTU.
- USB.

Ordering numbers for communication modules

- 175G9000 Modbus module.
- 175G9001 PROFIBUS module.
- 175G9002 DeviceNet module.
- 175G9009 MCD USB module
- 175G9904 Modbus TCP module.
- 175G9905 PROFINET module.
- 175G9906 Ethernet/IP module.

11.2.3 PC Software

WinMaster PC software provides:

- Monitoring.
- Programming.
- Control of up to 99 soft starters.

A Modbus or USB communication module is required for each soft starter to use WinMaster.

11.2.4 Finger Guard Kit

Finger guards may be specified for personnel safety. Finger guards fit over the soft starter terminals to prevent accidental contact with live terminals. Finger guards provide IP20 protection when correctly installed.

- MCD5-0131B to MCD5-0215B: 175G5662
- MCD5-0245B to MCD5-0396B: 175G5730
- MCD5-0469B to MCD5-0961B: 175G5731
- MCD5-245C: 175G5663
- MCD5-0360C to MCD5-0927C: 175G5664
- MCD5-1200C to MCD5-1600C: 175G5665

NOTICE

To be UL-compliant, the models MCD5-0131B to MCD5-0396B require finger guards.

11.2.5 Surge Protection Kit (Lightning Protection)

As standard, MCD 500 rated impulse withstand voltage is limited to 4 kV. The surge protection kits protect the system and make the soft starter immune to high-voltage impulses.

6 kV

- 175G0100 SPD Surge protection kit for G1
- 175G0101 SPD Surge protection kit, G2-G5

12 kV

- 175G0102 SPD Surge protection kit for G1
- 175G0103 SPD Surge protection kit, G1-G5

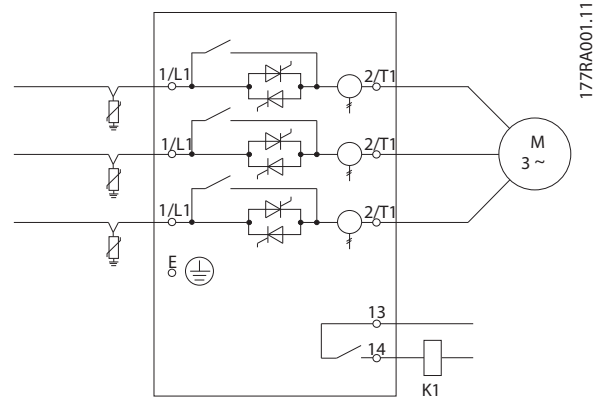

Illustration 11.1 System with Surge Protection Kit

12 Busbar Adjustment Procedure (MCD5-0360C to MCD5-1600C)

The busbars on non-bypassed models MCD5-0360C to MCD5-1600C can be adjusted for top or bottom input and output as required.

NOTICE

Many electronic components are sensitive to static electricity. Voltages so low that they cannot be felt, seen or heard, can reduce the life, affect performance, or completely destroy sensitive electronic components. When performing service, use proper ESD equipment to prevent possible damage from occurring.

All units are manufactured with input and output bus bars at the bottom of the unit as standard. If necessary, the input and/or output bus bars can be moved to the top of the unit.

1. Remove all wiring and links from the soft starter before dismantling the unit.
2. Remove the unit cover (4 screws).
3. Remove the LCP faceplate, then gently remove the LCP (2 screws).
4. Remove the control card terminal plugs.
5. Gently fold the main plastic away from the soft starter (12 screws).
6. Unplug the LCP loom from CON 1 (see *Notice*).
7. Label each SCR firing loom with the number of the corresponding terminal on the main control PCB, then unplug the looms.
8. Unplug the thermistor, fan, and current transformer wires from the main control PCB.
9. Remove the plastic tray from the soft starter (4 screws).

NOTICE

Remove the main plastic slowly to avoid damaging the LCP wiring loom which runs between the main plastic and the backplane PCB.

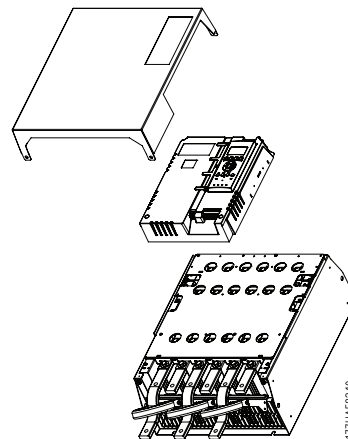

Illustration 12.1

10. Unscrew and remove the magnetic bypass plates (models MCD5-0620C to MCD5-1600C ONLY).
11. Remove the current transformer assembly (3 screws).
12. Identify which bus bars to remove. Remove the bolts holding these bus bars in place then slide the bus bars out through the bottom of the starter (4 bolts per bus bar).

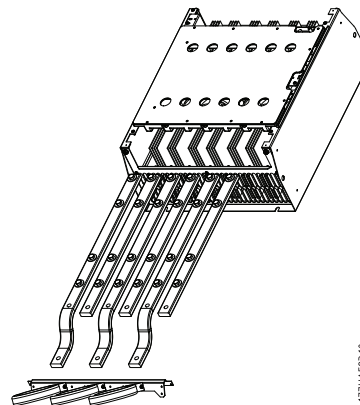

Illustration 12.2

13. Slide the bus bars in through the top of the starter. For input bus bars, place the short curved end outside the soft starter. For output bus bars, place the unthreaded hole outside the soft starter.
14. Replace the dome washers with the flat face towards the bus bar, then tighten the bolts holding the bus bars in place to 20 Nm.
15. Place the current transformer assembly over the input bus bars and screw the assembly to the body of the starter (see *Notice*).

16. Run all wiring to the side of the soft starter and secure with cable ties.

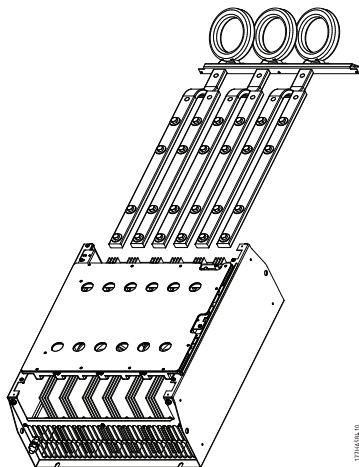

Illustration 12.3

NOTICE

If moving the input busbars, the current transformers must also be reconfigured.

1. Label the current transformers L1, L2, and L3 (L1 is leftmost when working from the front of the starter). Remove the cable ties and unscrew the current transformers from the bracket.
2. Move the current transformer bracket to the top of the starter. Position the current transformers for the correct phases, then screw the current transformers to the bracket. For models MCD5-0360C to MCD5-0930, place the current transformers on an angle. The left-hand legs of each current transformer are on the top row of holes and the right-hand legs are on the bottom tabs.

13 Appendix

13.1 Symbols, Abbreviations, and Conventions

°C	Degrees celsius
AC	Alternating current
DC	Direct current
DOL	Direct on-line
EMC	Electro magnetic compatibility
FLA	Full load amperage
FLC	Full load current
FLT	Full load torque
IP	Ingress protection
LCP	Local control panel
LRA	Locked rotor amps
MSTC	Motor start time constant
PAM	Pole amplitude modulated
PCB	Printed circuit board
PELV	Protective extra low voltage
PFC	Power factor correction
SCCR	Short circuit current rating
SELV	Safety extra low voltage
TVR	Timed voltage ramp

Table 13.1 Symbols and Abbreviations

Conventions

Numbered lists indicate procedures.

Bullet lists indicate other information.

Italicised text indicates:

- Cross reference.
- Link.
- Parameter name.

All dimensions are in [mm].

Index

A

Abbreviations..... 86

AC supply..... 16

AC1 rating..... 26

AC3 rating..... 26

AC-53 rating..... 22, 24

Access code..... 55, 58, 68, 70, 71, 72, 79

Accessories

 Connector kit..... 82

 see also *Pressure terminal*

 Finger guard kit..... 82, 83

 Pressure terminal..... 82

 see also *Connector kit*

 Surge protection kit..... 83

Alarm log..... 51, 72

Altitude..... 20, 22, 24, 26, 81

Ambient temperature..... 20, 22, 24, 26

Applications

 UL-compliant..... 31

Auto on mode..... 6, 50, 51, 52, 62, 65, 79

Auto-start..... 50, 65

Auto-start timer..... 64

Auto-stop..... 50, 65

B

Brake

 Brake..... 38, 39, 40, 50, 51, 60, 66, 67

 torque..... 39, 58, 60, 67

 DC brake..... 8, 39, 46, 79

 DC injection..... 39, 60, 67

 Full brake..... 39

 Pre-brake..... 39

 Soft brake..... 8

 Starter disable..... 8, 40, 62, 76, 77, 78

Bus bar..... 6

Busbar..... 15, 82, 84, 85

Busbar, input..... 16, 17

Busbar, output..... 16

Bypassed operation..... 22, 24

C

Calculated motor temperature..... 61

Capacitors

 Power factor correction capacitor..... 6, 26, 78

Certification..... 81

Communication modules

 DeviceNet..... 8, 82

 Ethernet..... 8, 82

 Ethernet/IP..... 82

 Modbus..... 8

 Modbus RTU..... 83

 Modbus TCP..... 82

 PROFIBUS..... 8, 82

 PROFINET..... 82

 USB..... 83

Connections

 In-line connection..... 8, 17, 19, 21, 22, 25, 26, 50, 74, 76, 80

 Inside delta..... 76

 Inside delta connection..... 8, 17, 23, 24, 25, 26, 40, 74, 79, 80

 Internal bypass..... 8

 Motor connection..... 8, 17, 19, 58, 69, 76

Contactors

 Bypass contactor.... 6, 17, 18, 19, 20, 21, 23, 26, 43, 69, 73, 75

 Bypass contactor overload..... 8

 High-speed contactor..... 48

 Internal bypass..... 69

 Low-speed contactor..... 48

 Main contactor..... 6, 18, 19, 20, 26, 42, 50, 51, 60, 63, 69, 77

 Star contactor..... 48

Continuous operation..... 22, 24, 40

Control supply..... 33, 34

Conventions..... 86

Counter..... 8, 55, 65, 68, 70, 72

Current flag..... 55, 58, 63, 64

Current imbalance..... 8, 40, 58, 60, 61, 65, 69, 73

D

Delay..... 47, 55, 58, 61, 63, 64, 65, 69, 77, 78

Direct on-line..... 36, 39, 69, 86

 see also *DOL*

DOL..... 36, 39, 69, 86

 see also *Direct on-line*

E

Electromagnetic capability..... 80

Environmental..... 81

Event log..... 8, 72, 73

Excess start time..... 8, 55, 56, 58, 60, 66, 69, 74

External zero-speed sensor..... 46, 47

F

Fan cooling..... 35

- Features
- Adaptive control... 8, 26, 35, 36, 37, 38, 40, 56, 59, 60, 66, 74, 79
 - Adaptive deceleration control..... 8
 - Coast to stop..... 37, 38, 39, 40, 50, 51, 60, 62, 66
 - DC brake..... 8, 39, 46, 79
 - Emergency run..... 8, 44, 45, 58, 62, 69
 - In-line connection..... 8, 17, 19, 21, 22, 25, 26, 50, 74, 76, 80
 - In-line installation..... 18, 19, 79
 - Inside delta..... 76
 - Inside delta connection..... 8, 17, 23, 24, 25, 26, 40, 74, 79, 80
 - Inside delta installation..... 19, 20, 79
 - Internal bypass..... 8, 69
 - Jog..... 8, 39, 40, 50, 51, 58, 62, 69, 77, 79
 - Kick start..... 8, 37, 58, 59, 66
 - Output signal simulation..... 8, 71
 - Output simulation..... 55
 - Protection simulation..... 8, 55, 71
 - Soft brake..... 8
 - Soft braking configuration..... 47
 - Starter disable..... 8, 40, 46, 62, 76, 77, 78
 - Thermal model..... 8, 35, 39, 40, 55, 67, 68, 70, 72
 - Timed voltage ramp..... 8, 37, 40, 60, 66, 86
see also *TVR*
 - TVR..... 8, 37, 40, 60, 66, 86
see also *Timed voltage ramp*
- FLC.... 17, 19, 25, 26, 31, 35, 37, 38, 53, 56, 59, 61, 64, 66, 74, 77, 78, 79, 86
see also *Full load current*
- FLT..... 40, 86
see also *Full load torque*
- Frequency trip..... 61
- Full load current..... 17, 19, 25, 26, 31, 35, 37, 38, 53, 56, 59, 61, 64, 66, 74, 77, 78, 79, 86
see also *FLC*
- Full load torque..... 40, 86
see also *FLT*
- Fuses
- British style (BS88)..... 28
 - Bussmann fuse..... 27
 - European style (PSC 690)..... 31
 - Ferraz..... 29, 32
 - Fuse..... 18, 20
 - Fuse recommendation..... 26
 - HRC fuse..... 26, 80
 - HSJ..... 29
 - Motor branch circuit..... 39
 - Motor rated mains fuse..... 26
 - North American Style (PSC 690)..... 30
 - Power supply fuse..... 26
 - Protection fuse..... 39
 - Semiconductor fuse..... 18, 19, 20, 26, 32, 42, 43, 80
 - Short circuit rating..... 31, 32
 - Square body..... 27
 - Type 1..... 26, 80
 - Type 2..... 26, 80
 - UL fuse selection..... 31
- G
- Gain setting..... 60, 66
- General fault messages..... 79
- H
- Hand on mode..... 50, 51, 52
 - Heat dissipation..... 81
 - Heat sink..... 6, 58, 69, 75
 - Heat sink temperature..... 8
- I
- Initial current..... 66
 - Input A trip..... 73, 75, 76, 77
 - Input rating..... 80
 - Input trip..... 8, 46, 62, 63
- Inputs
- Control input..... 17
 - Input A..... 40, 44, 45, 46, 47, 48, 49, 55, 58, 62, 63, 65, 69, 75, 76, 78, 79
 - Local control input..... 8
 - Power input..... 16
 - Programmable input..... 33, 34, 40, 69, 71, 73, 75, 76, 77, 78, 80
 - Remote..... 6, 13, 50, 51, 62, 65, 73
 - Remote control input..... 8, 33, 34, 42, 43, 44, 45, 47, 49
 - Reset..... 13, 63
- Inside delta current..... 17, 19
- Installation
- Bypass contactor..... 43
 - Clearance..... 10
 - Derating values..... 10
 - Dimension..... 12
 - Externally bypassed..... 18, 19
 - In-line installation..... 18, 19, 79
 - Inside delta installation..... 19, 20, 79
 - Internally bypassed..... 18, 19
 - Main contactor..... 42
 - Non-bypassed..... 18, 19
 - Side-by-side..... 10
 - UL-compliant..... 17, 82, 83
 - Weight..... 12
- Instantaneous overcurrent protection..... 61
- K
- Keys
- Control keys..... 50, 51, 52
 - LCP keys..... 62
 - Navigation keys..... 51
- L
- LCP..... 8, 13, 40, 50, 51, 52, 55, 57, 62, 65, 67, 68, 71, 73, 79, 82, 84, 86
see also *Local control panel*
 - Local control..... 14, 50, 51, 62, 78
 - Local control panel... 8, 13, 40, 50, 51, 52, 55, 57, 62, 65, 67, 68, 71, 73, 79, 82, 84, 86
see also *LCP*

Local mode..... 13, 62
 Locked rotor amp..... 31, 86
 see also *LRA*
 LRA..... 31, 86
 see also *Locked rotor amp*

M

Main menu..... 51, 55, 57, 70, 71, 77
 Models
 Internally bypassed..... 16, 17, 21, 23, 33, 75, 77
 Non-bypassed..... 17, 18, 20, 22, 26, 34, 69, 84
 Motor
 body..... 35
 connection..... 6, 8, 17, 19, 58, 69, 76
 temperature..... 78
 windings..... 35, 73, 76
 Overload..... 8, 35, 58, 59, 65, 69, 76
 Thermal behaviour..... 35
 Thermal capacity..... 35, 53, 61, 64, 76, 78
 Thermistor..... 8, 13, 33, 34, 39, 40, 42, 43, 44, 45, 47, 58, 65,
 69, 72, 76, 77, 79, 80, 84
 Motor branch protection..... 26
 Motor temperature..... 53, 54, 59, 64, 67, 68, 70, 71
 Motor temperature flag..... 63, 64

N

Network communication..... 76

O

Ordering
 form..... 9
 Type code..... 9
 Outputs
 Analog output..... 64
 Analog programmable output..... 8
 Output A..... 64
 Output relay B..... 43, 49
 Output relay C..... 48
 Power output..... 16
 Programmable output..... 18, 20, 60, 64, 71, 80
 Relay output..... 8, 17, 33, 34
 Relay output A..... 33, 34, 42, 43, 44, 45
 Relay output B..... 33, 34, 42, 43, 44, 45, 49
 Relay output C..... 33, 34, 42, 43, 44, 45
 Overcurrent..... 8, 55, 58, 61, 64, 65, 69, 75, 77

P

PC software..... 83
 Power factor..... 53, 64, 67, 68, 78
 Power factor correction..... 86
 Power loss..... 8, 65, 77
 Primary motor settings..... 47, 48, 59
 Programming details..... 51
 Protection settings..... 17, 59, 76

Q

Quick menu..... 51, 55
 Quick set-up..... 55

R

Relays
 Output relay..... 71
 Output relay A..... 42
 Output relay B..... 43, 49
 Output relay C..... 48
 Relay A..... 55, 58, 63, 71, 80
 Relay B..... 55, 58, 63, 80
 Relay C..... 55, 58, 63, 64, 80
 Remote control..... 13, 14, 50, 52, 62, 65, 78, 82
 Remote mode..... 13, 46, 62
 Restart delay..... 39, 40, 58, 61, 78
 Run modes
 Emergency run..... 8, 44, 45, 58, 69

S

Schematic diagrams
 Internally bypassed..... 33
 Secondary motor set..... 47, 48, 65
 Serial communication..... 13, 14, 50, 52, 62, 65
 Short circuit capability..... 80
 Shunt trip circuit breaker..... 26
 Speed profile..... 26
 Standards
 EU directive 2002/95/EC..... 81
 GB 14048-6..... 81
 IEC 60947-4-2..... 26, 80, 81
 IEC 61140..... 13
 Lloyds Marine No 1 Specification..... 81
 RoHS..... 81
 UL 508..... 31
 UL 508C..... 81
 Start current requirement..... 41
 Start modes
 Adaptive control.... 8, 26, 36, 37, 38, 40, 56, 59, 60, 66, 74, 79
 Constant current..... 8, 36, 37, 40, 56, 57, 59, 66
 Current ramp..... 8, 36, 37, 59, 66
 Jog..... 8, 39, 40, 50, 51, 58, 62, 69, 77, 79
 Kick start..... 8, 37, 58, 59, 66
 Start torque requirement..... 41
 Starting profile..... 35, 37, 79
 Status..... 51, 71
 Status details..... 51
 Status screen..... 52, 53, 70, 72

Stop modes		UL Indoor Type 1.....	81
Adaptive control.....	38, 60, 66	UL-listed.....	81
Adaptive deceleration control.....	8	UL-recognised.....	81
Brake.....	38, 39, 40, 50, 51, 60, 62, 66, 67	Undercurrent.....	8, 55, 58, 61, 64, 65, 69, 77
Coast to stop.....	37, 38, 39, 40, 50, 51, 60, 62, 66	Undercurrent protection.....	61
DC brake.....	8, 39, 46, 79		
Soft brake.....	8	W	
Starter disable.....	8, 40, 46, 62, 76, 77, 78	WinMaster.....	83
Timed voltage ramp.....	8, 37, 40, 60, 66, 86	Wiring	
see also <i>TVR</i>		Soft braking configuration.....	47
TVR.....	8, 37, 40, 60, 66, 86	Two-speed configuration.....	49
see also <i>Timed voltage ramp</i>			
Stop time.....	37, 38, 39, 40, 55, 56, 58, 60, 65, 66, 67, 79		
Stopping profile.....	35		
Suggested values.....	56, 57		
Supply.....	6, 8, 13, 26, 36, 39, 42, 43, 44, 45, 46, 47, 48, 49, 74, 75, 77, 78, 80		
Supply output.....	8		
Supply voltage.....	27, 28, 29, 30		
Symbols.....	86		
T			
Terminals			
A4.....	13, 75, 80		
A5.....	13, 75, 80		
A6.....	13, 75, 80		
Bypass.....	17		
Bypass terminal.....	18, 20, 34		
Control input.....	13		
Control terminal.....	13		
Power.....	15		
Relay terminal.....	13, 78		
Terminal 05.....	13, 77, 80		
Terminal 06.....	13, 77, 80		
Terminal 07.....	80		
Terminal 08.....	80		
Terminal 11.....	44, 45, 46, 62, 76, 78, 80		
Terminal 13.....	42, 69, 80		
Terminal 14.....	42, 69, 80		
Terminal 15.....	80		
Terminal 16.....	44, 45, 46, 62, 76, 78, 80		
Terminal 17.....	44, 45, 80		
Terminal 18.....	44, 45, 63, 80		
Terminal 21.....	43, 80		
Terminal 22.....	43, 80		
Terminal 24.....	43, 80		
Terminal 25.....	63, 80		
Terminal 33.....	80		
Terminal 34.....	80		
Thermal characteristics.....	35		
Thermal overload protection.....	35		
Trip categories.....	65		
Trip log.....	72		
Trip messages.....	78		
U			
UL Indoor Open Type.....	81		



.....
Danfoss can accept no responsibility for possible errors in catalogues, brochures and other printed material. Danfoss reserves the right to alter its products without notice. This also applies to products already on order provided that such alterations can be made without subsequential changes being necessary in specifications already agreed. All trademarks in this material are property of the respective companies. Danfoss and the Danfoss logotype are trademarks of Danfoss A/S. All rights reserved.
.....

